

MITSUBISHI

三菱工業用ミシン部品カタログ

Industrial Sewing Machine Parts Catalog

Model **PLK-B4516**
PLK-B4516L
PLK-B6019

目次	CONTENTS	Page
[A] 全 体 構 成	Construcion	1
[B] 本 体 関 係 (I)	Arm bed & It's accessories (I)	2
[C] 本 体 関 係 (II)	Arm bed & It's accessories (II)	4
[D] 本 体 関 係 (III)	Arm bed & It's accessories (III)	6
[E] 本 体 関 係 (IV)	Arm bed & It's accessories (IV)	8
[F] 縫 い 機 構 (I)	Sewing mechanism (I)	10
[G] 中 押 え 機 構 (I)	Presser bar lifting mechanism (I)	12
[H] 中 押 え 機 構 (II)	Presser bar lifting mechanism (II)	14
[J] 糸 切 り 機 構	Thread trimming mechanism	16
[K] X-Y テーブル機構 (I)	X-Y Table mechanism (I)	18
[L] X-Y テーブル機構 (II)	X-Y Table mechanism (II)	20
[M] 外 押 え 機 構 (I)	Work holder mechanism (I)	22
[N] ワイパー機構、上軸検出機構	Wiper mechanism, uper shaft detection mechanism	24
[P] 給 油 機 構	Oil lubrication mechanism	26
[Q] 配 線 , 配 管 関 係	Cable component & pneumatic control unit	28
[R] テーブル関係	Table & stand	30
[S] 附 属 品 (I)	Accessories (I)	32
[V] オプションパーツ	Option parts	34
索 引	Index	36

部品コードの採番形式 MITSUBISHI SPARE PARTS No. Designation system

1. 部品コードについて CONCERNING PARTS CODE.
 部品をご注文される場合は、部品コードをお知らせください。
 Please inform the part number, when these parts are ordered.

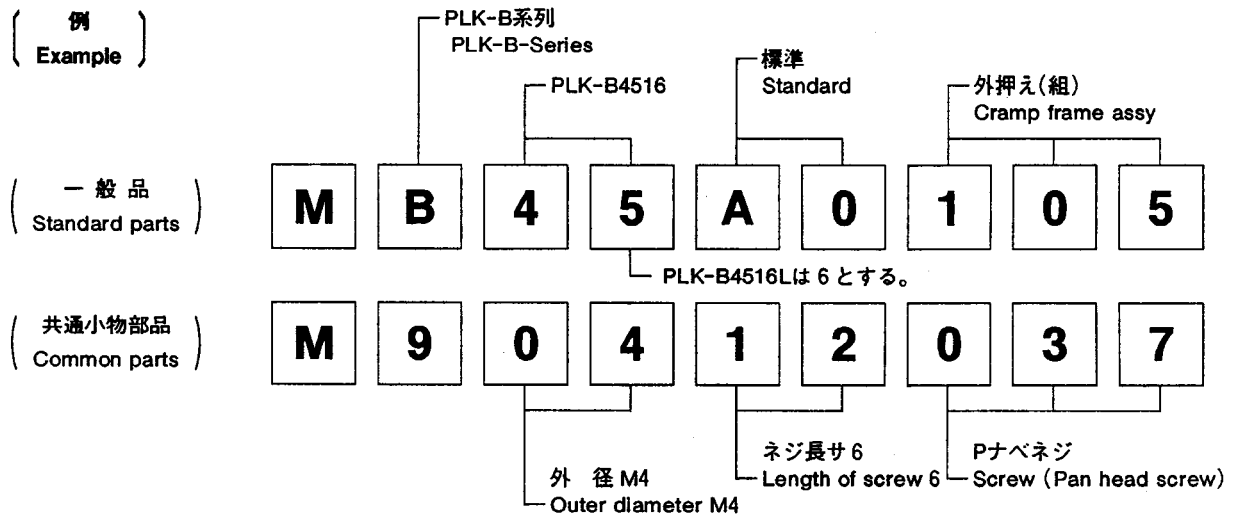
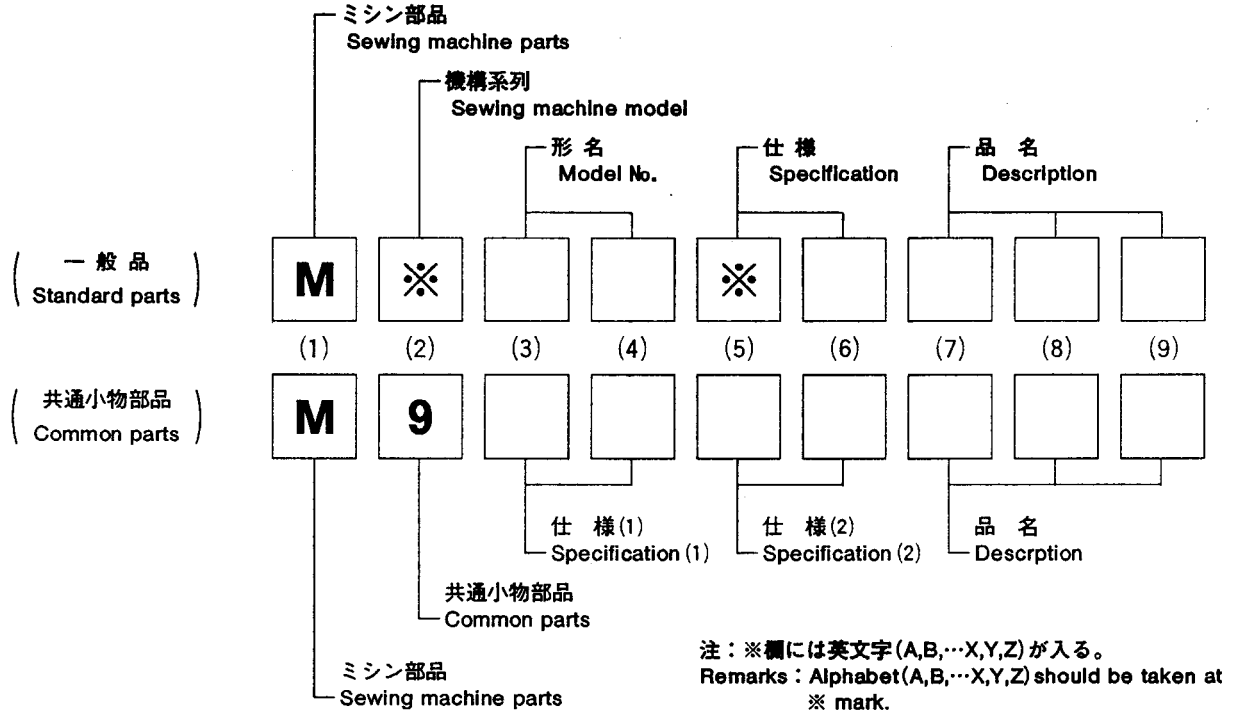

2. 変更マークについて CONCERNING MODIFICATION MARK.
 変更マーク欄に*記号の記載のある部品は、形状、寸法等の変更履歴がありますので、ご注文の際にはご使用のミシンの製造番号と併せてご連絡ください。
 The parts marked with * in the modification column has been changed the shape or size etc. So when these modified parts are ordered please inform the serial number of the sewing machine.

注：一般品についての機種形名は、その部品が最初に使用された機種形名を示します。従って長期に亘る場合は、機種の改廃が行われるため、当初の機種以外の機種で使用されている場合があります。
 Sewing machine Models, of Standard Parts are indicated model of these parts are registered firstly. Parts are used for not only the indicated model, but also another models, in reason of New development, improvement after.

A 本体構成
CONSTRUCTION

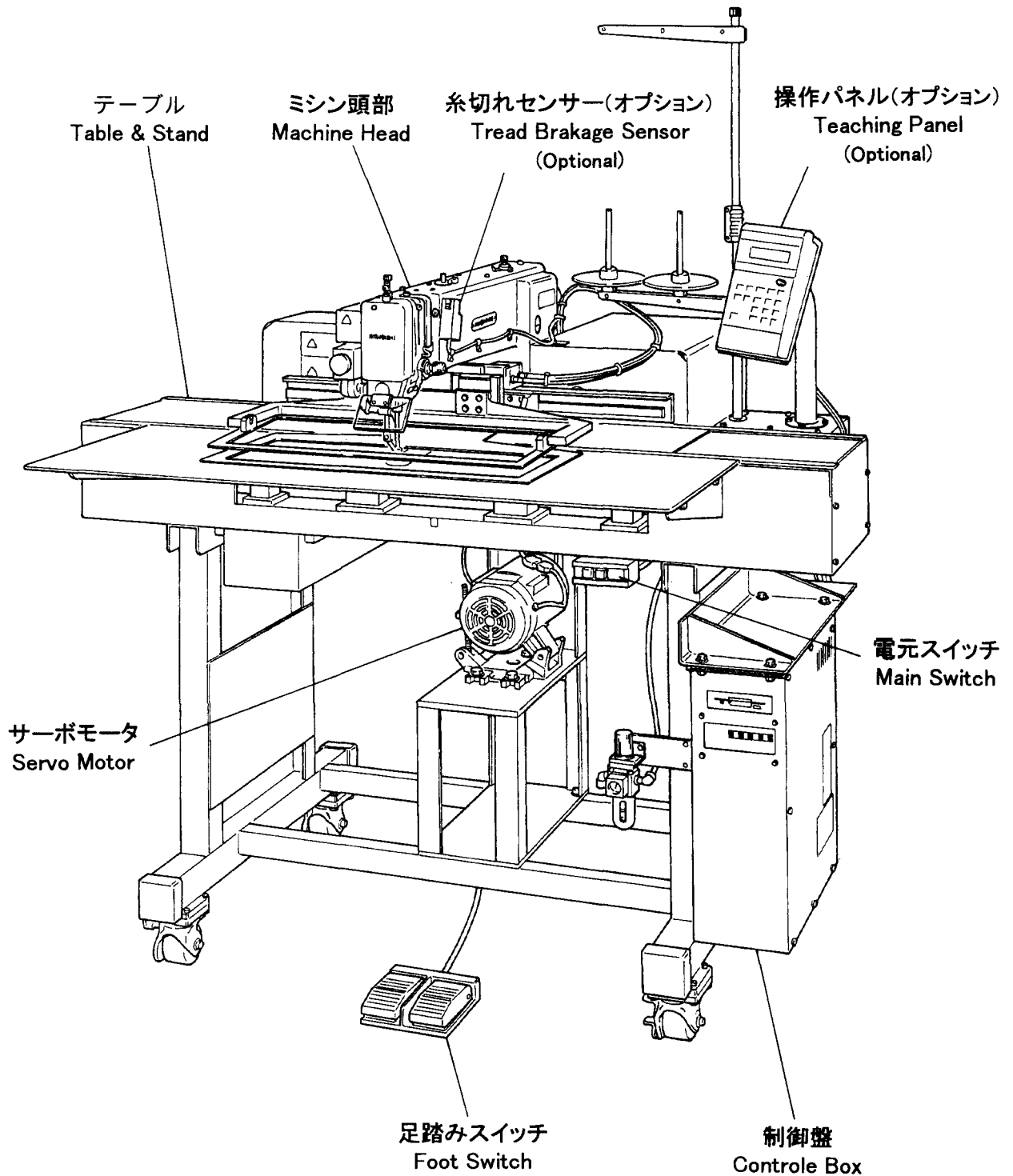

B 本体関係 (I)
ARM BED AND IT'S ACCESSORIES (I)

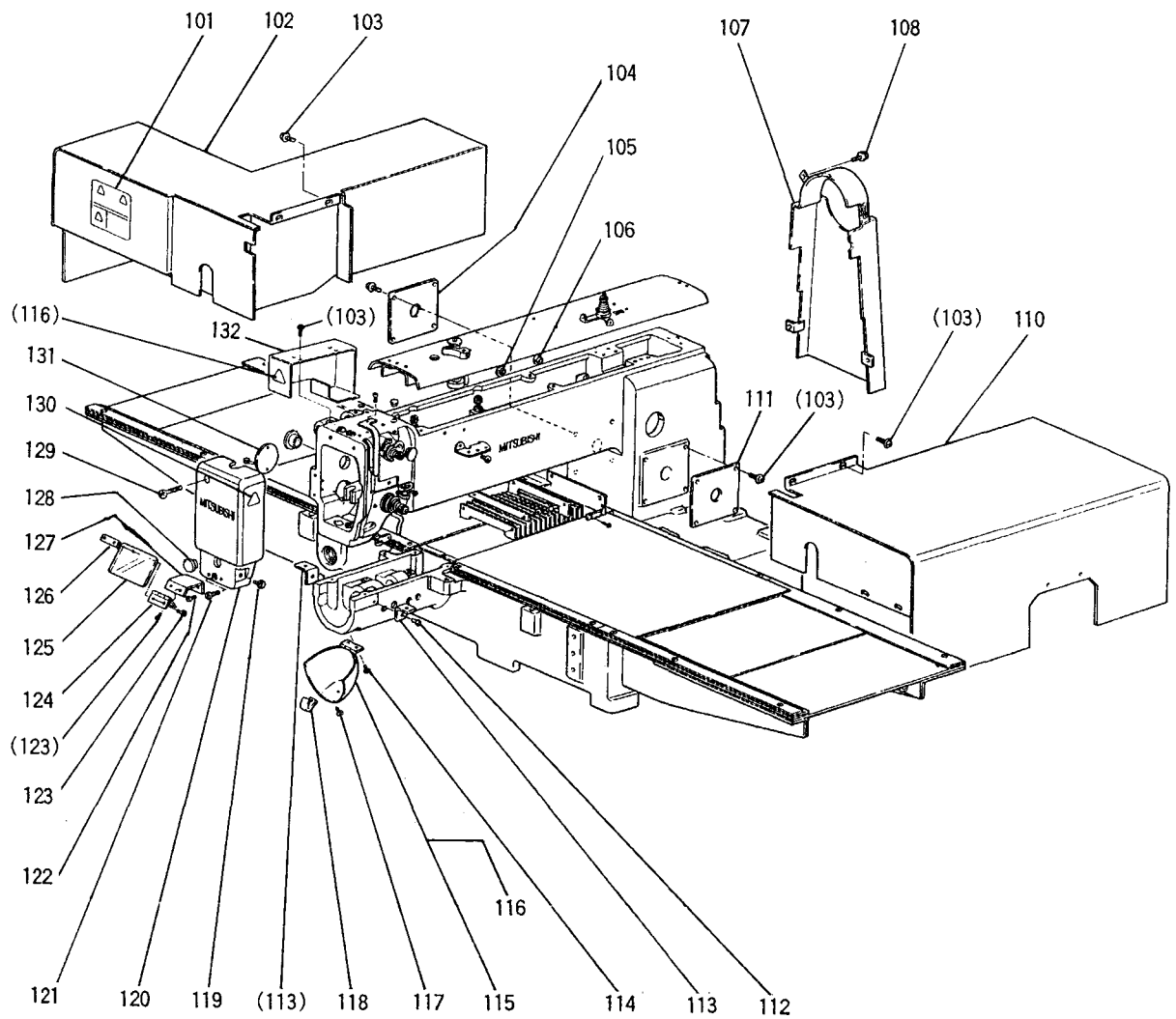

Fig No.	部品コード Parts No.	品名	Description	数量 Amt. Req.		
				B4516	B4516L	B6019
B101	MB61A0459	ケイコクシール(リウサ)	Warning seal (operation)	1	1	1
B102	MA45A0849	モータカバー	Motor cover	1	1	1
B103	M91054004	SW-PWフ°ラマイナヘネジ M4×8	Screw M4×8	11	11	11
B104	MA45A0339	カバー	Cover	1	1	1
B105	M90883080	ゴムセシ	Rubber plug	3	3	3
B106	M91304080	ゴムセシ	Rubber plug	3	3	3
B107	MA45A0776	ベルトカバー	Belt cover	1	1	1
B109	M91330004	SW-PWフ°ラマイナヘネジ M5×8	Screw M5×8	3	3	3
B110	MA45A1849	モータカバー	Motor cover	1	1	1
B111	MA45A3339	カバー	Cover	1	1	1
B112	M94001017	セフティソケット M4×10	Bolt M4×10	2	2	2
B113	MS14A1601	トリツケイタ	Bracket	2	2	2
B114	M90859004	SW-PWフ°ラマイナヘネジ M3×6	Screw M3×6	2	2	2
B115	MB60E6339	シリンダ-カバー-(クミ)	Cylinder cover complete	1	1	1
B116	MB61A2459	ケイコクシール(ケカ)	Warning seal (injury)	2	2	2
B117	M90906003	マルヒラネジ(40)×3.2	Screw (40)×3.2	4	4	4
B118	MS01A0361	カケカネ	Latch	1	1	1
B119	M90909003	マルヒラネジ(40)×6	Screw (40)×6	1	1	1
B120	MB60E0830	メンイタクミタテ	Fase plate	1	1	1
B121	M90442037	フ°ラマイナヘネジ M4×16	Screw M4×16	1	1	1
B122	M91110002	ヒラネジ 11/64(40)×8	Screw 11/64(40)×8	2	2	2
B123	M90806002	ヒラネジ 1/8(44)×6	Screw 1/8(44)×6	4	4	4
B124	MS01A1739	ヒンジ	Hinge	1	1	1
B125	MS01A0160	アイガード	Eye guard	1	1	1
B126	MS01A0477	アダカネ	Adapter	1	1	1
B127	MB60A0601	アイガードトリツケイタ	Eye guard adapter	1	1	1
B128	M91910080	ゴムセシ	Rubber plug	1	1	1
B129	M90432038	フ°ラマイナヘネジ M4×30	Screw M4×30	1	1	1
B131	MA35A5339	カバー	Cover	1	1	1
B132	MB61A2339	リンクカバー	Link cover	1	1	1

C 本体関係 (II)
 ARM BED AND IT'S ACCESSORIES (II)

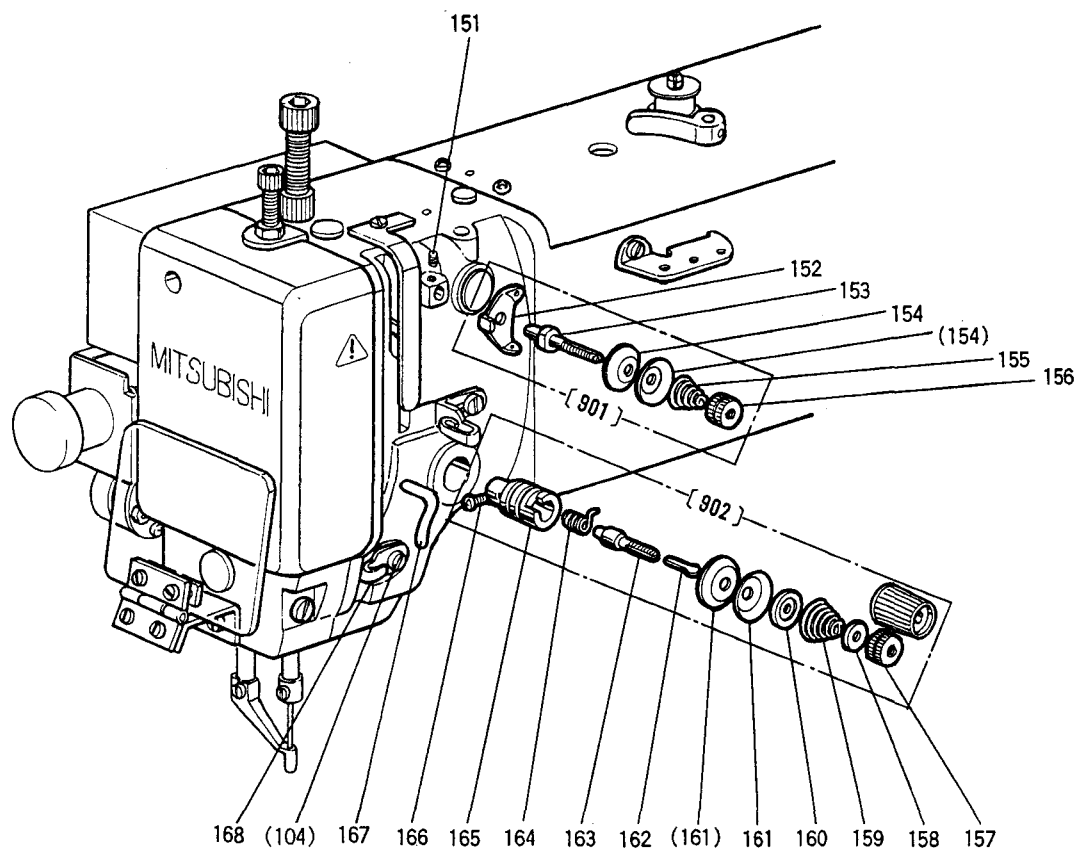
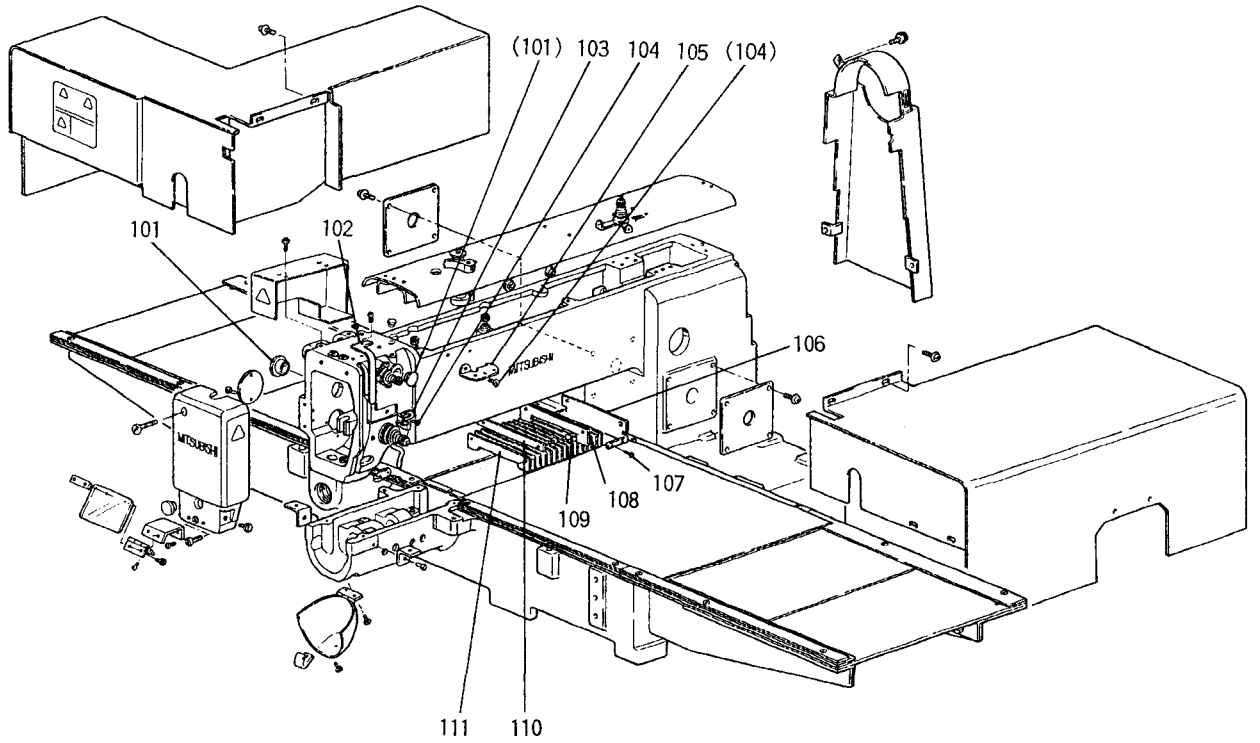

Fig No.	部品コード Parts No.	品名	Description	数量 Amt. Req.		
				B4516	B4516L	B6019
C101	M91910080	ゴムセシ	Rubber plug	4	4	4
C102	MA20A0584	テンヒンカハ	Thread take-up cover	1	1	1
C103	MG43A0181	イトアンナイ(ナカ)	Thread guide	1	1	1
C104	M90990002	ヒラネシ M4×8	Screw M4×8	2	2	2
C105	MF36A1180	イトアンナイ	Thread guide	1	1	1
C106	MA45A0226	シヤハラトリツケイタ	Shutter adapter	1		
C107	M91058004	SW-PWフ°ラマイナハネシ M4×6	Screw M4×6	4		
C108	MA45A0257	オサエイタ	Shutter holder	1		
C109	M90859004	SW-PWフ°ラマイナハネシ M3×6	Screw M3×6	4		
C110	MA45A1257	オサエイタ	Shutter holder	1		
C111	MA45A0458	シヤハラ	Shutter	1		
C151	M91053020	ロツカクアナツキトメネシ M4×6	Screw M4×6	1	1	1
C152	MF90A0181	イトアンナイ(フ°リテンション)	Thread guide	1	1	1
C153	MF00A0553	チョウシホウ	Thread tension stud	1	1	1
C154	MF10A1555	チョウシサラ	Thread tension discs	2	2	2
C155	MF36A0245	エンスイハネ	Thread tension spring	1	1	1
C156	M91101046	ツマミナツト	Thumb nut	1	1	1
C157	M91605045	チョウセツナツト	Thumb nut	1	1	1
C158	MT60A0802	カイリトメ	Thumb nut revolution stopper	1	1	1
C159	MN50A1245	エンスイハネ	Thread tension spring	1	1	1
C160	MM11A0556	チョウシサラオサエ	Thread tension releasing disc	1	1	1
C161	MF10A0555	チョウシサラ	Thread tension discs	2	2	2
C162	M90204060	ピン	Thread tension releasing pin	1	1	1
C163	MF10A0553	チョウコホウ	Thread tension stud	1	1	1
C164	MF10A0187	イトトリリハネ	Thread take-up spring	1	1	1
C165	MF10A0709	フ°ツシ	Bushing	1	1	1
C166	M90901002	ヒラネシ 9/64(40)×4	Screw 9/64(40)×4	1	1	1
C167	MF10A0181	イトアンナイ(シタ)	Thread guide	1	1	1
C168	MF70A1180	イトアンナイ	Thread guide	1	1	1
C901	MF00E0550	チョウセツキ(クミ)(フ°リテンション)	Pre-tension complete	1	1	1
C902	MA16E0210	ウライトチョウセツキ(クミ)	Thread tension regulator	1	1	1

D 本体関係 (Ⅲ)
 ARM BED AND IT'S ACCESSORIES (Ⅲ)

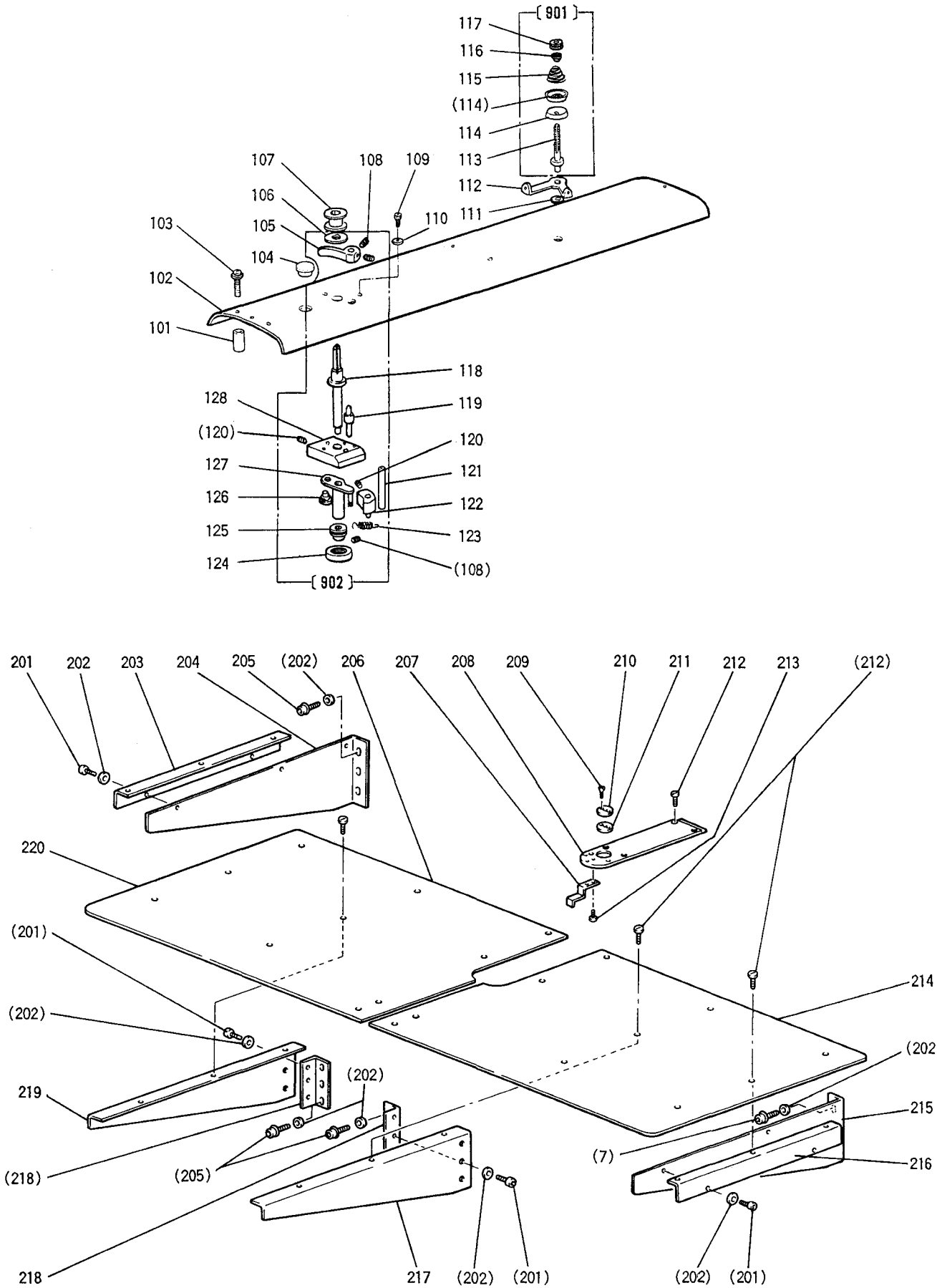

Fig No.	部品コード Parts No.	品名	Description	数量Amt. Req.		
				B4516	B4516L	B6019
D101	MB62A0352	スヘ-サ	Spacer	5	5	5
D102	MB45A0600	トップカバー	Top cover	1	1	1
D103	M91076004	SW-PWツキフアラマイハネシ M4×30	Screw M4×30	5	5	5
D104	M91910080	ゴムセン	Rubber plug	1	1	1
D105	MA20A1950	レバ-	Lever	1	1	1
D106	MA20A0476	スヘ-サ	Spacer	1	1	1
D107	MA10A0123	ホビ-ン	Bobbin	1	1	1
D108	M91057020	ロツカクアナツキトメネシ M3×4	Screw M3×4	4	4	4
D109	M94002017	セフテソケット M4×8	Bolt M4×8	2	2	2
D110	M90421050	サカネ 4	Washer 4	3	3	3
D111	MG75A1476	スヘ-サ	Spacer	1	1	1
D112	MS14A1180	イトアンナイ	Thread guide	1	1	1
D113	MS14A0553	チヨウシホウ	Thread tension stud	1	1	1
D114	MF10A0555	チヨウシガラ	Thread tension disc	2	2	2
D115	MM11A0245	エンスイハネ	Thread tension spring	1	1	1
D116	MM11A0702	ハネアンナイ	Spring guide	1	1	1
D117	M91602046	ツマミナット	Thumb nut	1	1	1
D118	MA04A1530	タンツキシク	Driven shaft	1	1	1
D119	MA04A2530	タンツキシク	Shaft	1	1	1
D120	M91055020	ロツカクアナツキトメネシ M4×4	Screw M4×4	2	2	2
D121	M90601064	スプリングピン 6×56	Spring pin 6×56	1	1	1
D122	MS14A0350	カム	Cam	1	1	1
D123	MS14A0572	ツルマキハネ	Helical spring	1	1	1
D124	MS03A0417	ゴムワ	Tire	1	1	1
D125	MA20A0194	イトマキグルマ	Wheel	1	1	1
D126	M99006063	ツハツキシク	Pin	1	1	1
D127	MB60E2750	ブッシュクミタテ	Bushing assy	1	1	1
D128	MB60A1601	トリツタダイ	Bracket	1	1	1
E901	MS14E0180	チヨウセツキクミタテ	Thread tension regulator assy	1	1	1
E902	MB60E0190	イトマキソウチ	Bobbin winder assy	1	1	1
D201	M95003017	セフテソケット M5×8	Bolt M5×8	10	10	10
D202	M90511050	サカネ 5	Washer 5	22	22	22
D203	MA45A2426	サエカナク(ヒタリ)	Bracket (L)	1	1	1
D204	MA45A1361	Lカクナク(ヒタリ)	L-Bracket (L)	1	1	
	MA61A1361	Lカクナク(ヒタリ)	L-Bracket (L)			1
D205	M95002017	セフテソケット M5×12	Bolt M5×12	12	12	12
D206	MA45A0473	スヘリイタ(ヒタリ)	Slide plate (L)	1	1	
	MA61A0473	スヘリイタ(ヒタリ)	Slide plate (L)			1
D207	MS01A0192	イタハネ	Leaf spring	1	1	1
D208	MB45A0472	スヘリイタ	Slide plate	1	1	1
D209	M90605010	サラネシ(56)×2.8	Screw (56)×2.8	2	2	2
D210	MS03A1101	ハリイタ	Needle plate	1	1	1
D211	MS01A1476	スヘ-サ	Spacer	1	1	1
D212	M90990002	ヒラネシ M4×8	Screw M4×8	20	20	20
D213	M90906003	マルヒラネシ 9/64(40)×3.2	Screw 9/64(40)×3.2	2	2	2
D214	MA45A0474	スヘリイタ(ミキ)	Slide plate (R)	1	1	
	MA61A0474	スヘリイタ(ミキ)	Slide plate (R)			1
D115	MA45A0361	Lカクナク(ミキ)	L-Bracket (R)	1	1	
	MA61A0361	Lカクナク(ミキ)	L-Bracket (R)			1
D216	MB45A0426	サエカナク(ミキ)	Bracket (R)	1	1	1
D217	MB45A1426	サエカナク(ミキ)	Bracket (R)	1	1	1
D218	MA20A0361	Lカクナク	L-Bracket	2	2	2
D219	MB45B1426	サエカナク(ヒタリ)	Bracket (L)	1	1	1
D220	MA45A0797	ホコフィルム	Slide plate guard film	1	1	
	MA61A0797	ホコフィルム	Slide plate guard film			1

㊦ 本体関係 (Ⅳ)
ARM BED AND IT'S ACCESSORIES (Ⅳ)

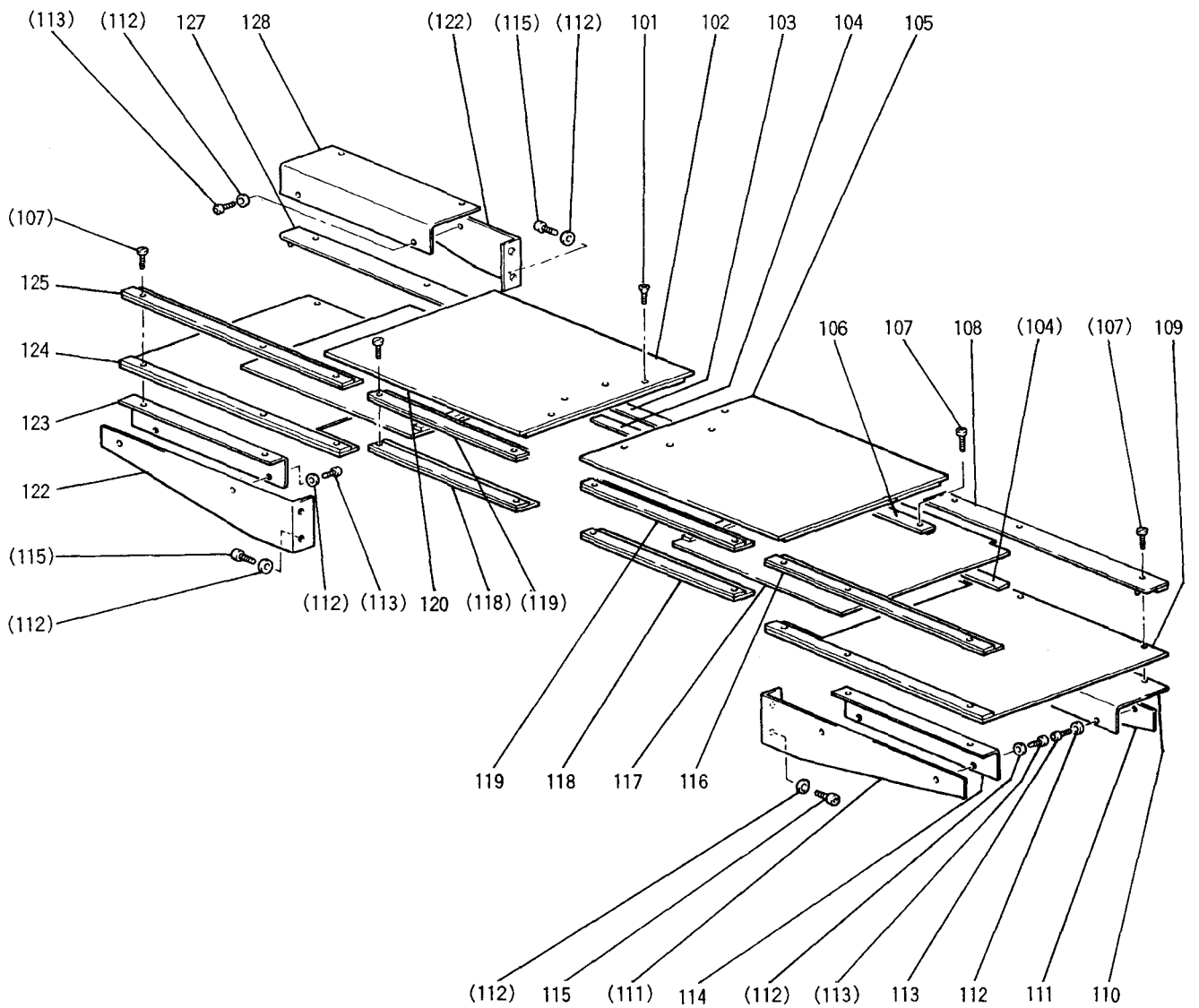

Fig No.	部品コード Parts No.	品名	Description	数量 Amt. Req.		
				B4516	B4516L	B6019
E101	M90352037	Pサネシ M3×6	Screw M3×6	8	8	8
E102	MA45A4339	Xカバー-イタ(ヒタリ)	X-Cover plate (L)	1	1	
	MA61A4339	Xカバー-イタ(ヒタリ)	X-Cover plate (L)			1
E103	MB45B1359	カバー-カイト(ヒタリ)	Cover guide (L)	1	1	
	MA61A0359	カバー-カイト(ヒタリ)	Cover guide (L)			1
E104	MB45A0476	スペーサ	Spacer	2	2	2
E105	MA45A5339	Xカバー-イタ(ミキ)	X-Cover plate (R)	1	1	
	MA61A5339	Xカバー-イタ(ミキ)	X-Cover plate (R)			1
E106	MB45A1359	カバー-カイト(ミキ)	Cover guide (R)	1	1	
	MA61A1359	カバー-カイト(ミキ)	Cover guide (R)			1
E107	M90990002	ヒラネシ M4×8	Screw M4×8	20	20	20
E108	MB45A2359	カバー-カイト(ミキ)	Cover guide (R)	1	1	
	MB69A0359	カバー-カイト(ミキ)	Cover guide (R)			1
E109	MB45A0339	X-Yカバー-(ミキ)	Cover (R)	1	1	
	MB69A0339	X-Yカバー-(ミキ)	Cover (R)			1
E110	MB45A2426	サエカナク(ミキ)	Bracket (R)	1	1	
	MB69A0426	サエカナク(ミキ)	Bracket (R)			1
E111	MA45A2361	Lカタカナク(ミキ)	L-Bracket (R)	1	1	
	MA61A2361	Lカタカナク(ミキ)	L-Bracket (R)			1
E112	M90511056	サカネ 5	Washer 5	8	8	8
E113	M95003017	セフティナット M5×8	Bolt M5×8	8	8	8
E114	MB45A3426	サエカナク(ミキ)	Bracket (R)	1	1	
	MB69A1426	サエカナク(ミキ)	Bracket (R)			1
E115	M95002017	セフティナット M5×12	Bolt M5×12	8	8	8
E116	MA45A3359	カバー-カイト(ミキ)	Cover guide (R)	1	1	
	MA61A3359	カバー-カイト(ミキ)	Cover guide (R)			1
E117	MB45A1339	Xイトウカバー-(ミキ)	X-Movable cover (R)	1	1	
	MB69A1339	Xイトウカバー-(ミキ)	X-Movable cover (R)			1
E118	MB45A1476	スペーサ	Spacer	2	2	2
E119	MA45A0359	カバー-カイト	Cover guide	2	2	2
E120	MB45B1339	Xイトウカバー-(ヒタリ)	X-Movable cover (L)	1	1	
	MB69B1339	Xイトウカバー-(ヒタリ)	X-Movable cover (L)			1
E122	MA45A3361	Lカタカナク(ヒタリ)	L-Bracket (L)	1	1	
	MA61A3361	Lカタカナク(ヒタリ)	L-Bracket (L)			1
E123	MB45B3426	サエカナク(ヒタリ)	Bracket (L)	1	1	
	MB69B1426	サエカナク(ヒタリ)	Bracket (L)			1
E124	MB45B0339	X-Yカバー-(ヒタリ)	Cover (L)	1	1	
	MB69B0339	X-Yカバー-(ヒタリ)	Cover (L)			1
E125	MA45A6359	カバー-カイト(ヒタリ)	Cover guide (L)	1	1	
	MA61A6359	カバー-カイト(ヒタリ)	Cover guide (L)			1
E127	MB45B2359	カバー-カイト(ヒタリ)	Cover guide (L)	1	1	
	MB69B0359	カバー-カイト(ヒタリ)	Cover guide (L)			1
E128	MB45B2426	サエカナク(ヒタリ)	Bracket (L)	1	1	
	MB69B0426	サエカナク(ヒタリ)	Bracket (L)			1

F 縫い機構 (I)
SEWING MECHANISM (I)

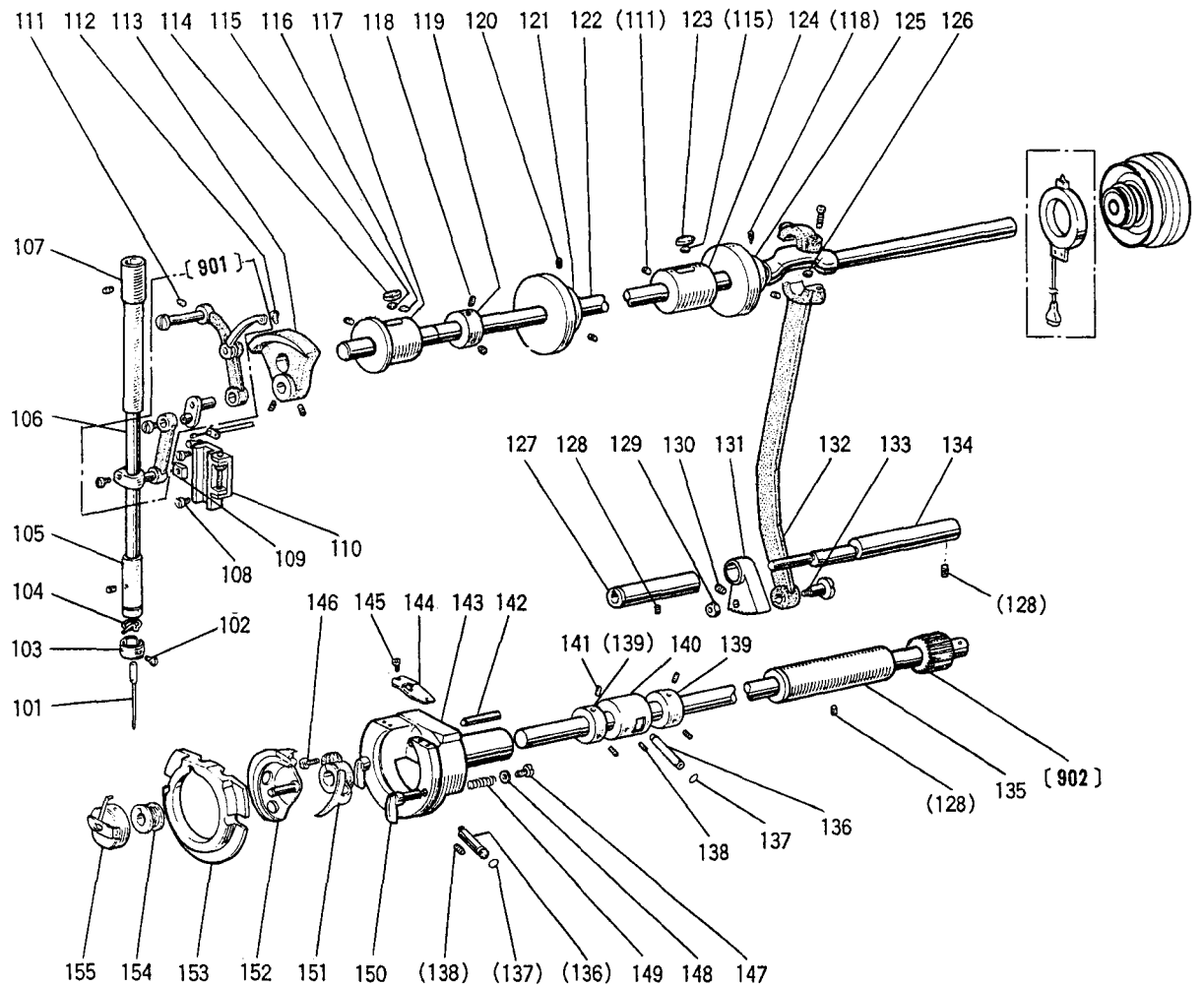

Fig No.	部品コード Parts No.	品名	Description	数量Amt. Req.		
				B4516	B4516L	B6019
F101	MS02A0128	ミシンハ*リDP×17 #18	Needle DP×17 #18	1	1	1
F102	M90815002	ヒラネジ*1/8(44)×4.5	Screw 1/8(44)×4.5	1	1	1
F103	MF21D0181	イトアンナイ	Thread guide	1	1	1
F104	MF01A0181	イトアンナイ	Thread guide	1	1	1
F105	MG30A0664	ハリホ*ウメタル(シタ)	Needle bar bushing (lower)	1	1	1
F106	MS01A0660	ハリホ*ウ	Needle bar	1	1	1
F107	MS01A0663	ハリホ*ウメタル(ウエ)	Needle bar bushing (upper)	1	1	1
F108	M90990002	ヒラネジ*M4×8	Screw M4×8	2	2	2
F109	MF10A0325	カクコマ	Square block	1	1	1
F110	MS03E0662	ハリカ*イト*(クミ)	Guide complete	1	1	1
F111	M91221001	トメネジ*M5×12	Screw M5×12	2	2	2
F112	M91802006	ホ*ウサキヒラネジ*	Screw	1	1	1
F113	MS01A0383	クランク	Crank	1	1	1
F114	MA20A0740	フェルト	Felt	1	1	1
F115	MS10A1740	フェルト	Felt	2	2	2
F116	MV88A0740	フェルト	Felt	1	1	1
F117	MS10A0232	ウワシ*クメタル(ヒタ*リ)	Arm shaft bushing (left)	1	1	1
F118	M91602001	トメネジ*1/4(40)×4	Screw 1/4(40)×4	4	4	4
F119	MF70A0352	カラー	Collar	1	1	1
F120	M94006021	ロツカクアナツキトメネジ*M4×6	Screw M4×6	2	2	2
F121	MS14A0682	フ*ーリー	Pulley	1	1	1
F122	MA20A0230	ウワシ*ク	Arm shaft	1	1	1
F123	MF60A2740	フェルト	Felt	1	1	1
F124	MS10A0234	ウワシ*クメタル(ナカ)	Arm shaft bushing (middle)	1	1	1
F125	MS01A0350	イトキリカム	Thread trimmer cam	1	1	1
F126	MB60A0740	フェルト	Felt	1	1	1
F127	MS01A0833	メタル	Bushing	1	1	1
F128	M91222001	トメネジ*M5×6	Screw M5×6	3	3	3
F129	M91802045	ナット	Nut	1	1	1
F130	M95004021	ロツカクアナツキトメネジ*M5×5	Screw M5×5	1	1	1
F131	MS01A0508	セクタハク*ルマ	Sector gear	1	1	1
F132	MB45A0956	レンセツカン	Connecting rod	1	1	1
F133	M98003015	タ*ンツキヒラネジ* M8	Screw M8	1	1	1
F134	MS01A0891-	ウオト*ウシ*ク	Rock shaft	1	1	1
F135	MS03A8833	メタル	Hook shaft bushing	1	1	1
F136	MS01A0761	ハンシンシ*ク	Eccentric shaft	1	1	1
F137	M90502085	Oリング*	O-ring	1	1	1
F138	M91559001	クホ*ミサキトメネジ*M6×6	Screw M6×6	2	2	2
F139	MM11A0352	カラー	Collar	2	2	2
F140	MB62A0453	シタシ*クメタル(ナカ)	Hook shaft bushing (middle)	1	1	1
F141	M91503001	トメネジ*15/64(28)×4.5	Screw 15/64(28)×4.5	4	4	4
F142	M90001060	ヘイコウヒ*ンm6-4×18	Pin m6-4×18	1	1	1
F143	MS01A0121	ソトカ*マ	Outer hook	1	1	1
F144	MS01A0329	カマイトアンナイ	Thread guide	1	1	1
F145	M90853002	ヒラネジ*1/8(40)×4	Screw 1/8(40)×4	2	2	2
F146	M95001021	ロツカクアナツキホ*ルトM5×16	Bolt M5×16	1	1	1
F147	M90802003	マルヒラネジ*1/8(44)×4.5	Screw 1/8(44)×4.5	2	2	2
F148	M93006050	ザ*カ*ネ3.5	Washer 3.5	2	2	2
F149	MS01A0572	ツルマキハ*ネ	Spring	2	2	2
F150	MS09A0950	カマオサエツマミ	Hook clamp	2	2	2
F151	MS01A0611	ト*ライハ*ー	Hook driver	1	1	1
F152	MA10A0120	ナカカ*マ	Inner hook	1	1	1
F153	MS01A0616	ナカカ*マオサエ	Hook retainer	1	1	1
F154	MA10A0123	ホ*ヒ*ン	Bobbin	1	1	1
F155	MS17A0125	ホ*ヒ*ンケース	Bobbin case	1	1	1
F901	MS01E0580	デンヒ*ンハリククミタテ	Thread take-up lever assy	1	1	1
F902	MA20E0450	シタシ*ククミタテ	Hook shaft complete	1	1	1

G 中押え機構 (I)
PRESSER BAR LIFTING MECHANISM (I)

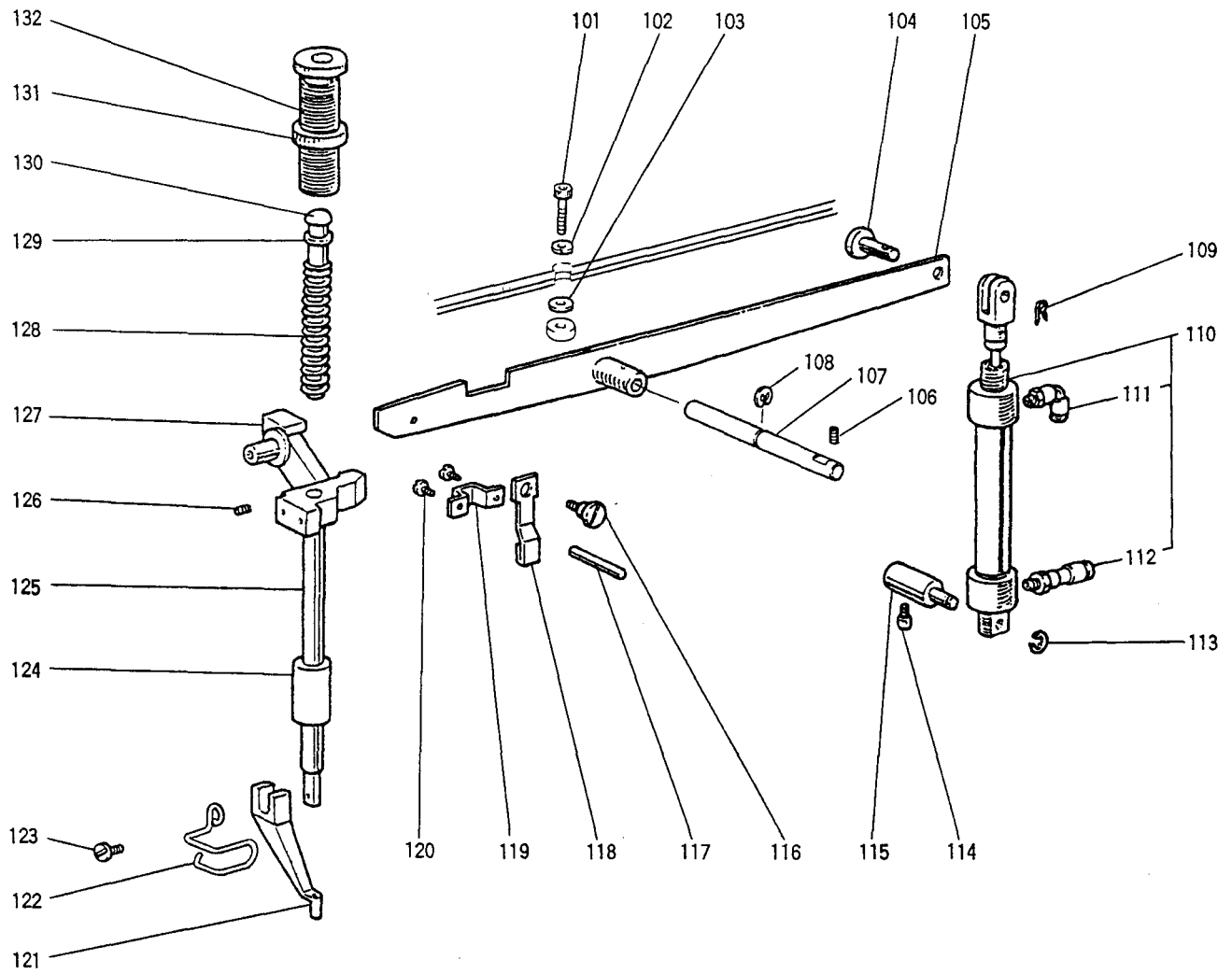

Fig No.	部品コード Parts No.	品名	Description	数量Amt. Req.		
				B4516	B4516L	B6019
G101	M99001021	ロツカクアナツキボルトM8×40	Bolt M8×40	1	1	1
G102	M92075045	ナツトM8	Nut M8	1	1	1
G103	M90823050	サカネ8	Washer 8	1	1	1
G104	M99008063	タンツキピン	Pin	1	1	1
G105	MA20A0252	オサエケレバ-	Lifting lever	1	1	1
G106	M91051020	ロツカクアナツキトメネシM4×8	Screw M4×8	1	1	1
G107	MA20A0454	シク	Shaft	1	1	1
G108	M90604065	エカトメ78	E-type retaning ring 8	1	1	1
G109	M90810060	スナツフピン8	Snap pin 8	1	1	1
G110	MB62A0434	エアシリンダ	Air cylinder	1	1	1
G111	MS53A3571	ワツタツキツキテ(エルホ)	Quick joint	1	1	1
G112	MA16A0571	ワツタツキツキテ(ストレート)	Quick joint	1	1	1
G113	M90511065	エカトメ76	E-Type retaining ring 6	1	1	1
G114	M95003021	ロツカクアナツキボルトM5×12	Bolt M5×12	1	1	1
G115	MS10A0530	タンツキシク	Shaft	1	1	1
G116	M91225015	タンツキヒラネシ3/16(28)×5.5	Screw 3/16(28)×5.5	1	1	1
G117	M90427060	イトルメピン	Thread releasing pin	1	1	1
G118	MG30B1222	イトルメ	Thread releasing cam	1	1	1
G119	MG30A0154	アンナイカネ	Guide plate	1	1	1
G120	M91058004	SW-PWツキアラマイナネシM4×6	Screw M4×6	2	2	2
G121	MV30A0256	ナカオサエ(φ3)	Presser foot (φ3)	1	1	1
G122	MB62A0626	ニートルカート	Finger protector	1	1	1
G123	M90922002	ヒラネシ9/64(40)×8	Screw 9/64(40)×8	1	1	1
G124	MF10A0267	オサエホウメタル	Presser bar bushing	1	1	1
G125	MS03A0262	オサエホウ	Presser bar	1	1	1
G126	M91506001	アタマナシトメネシ15/64(28)×7	Screw 15/64(28)×7	1	1	1
G127	MG10B0265	オサエホウタキ	Presser bar holder	1	1	1
G128	MS03A1572	オサエハネ	Presser bar spring	1	1	1
G129	M90625050	コサカネ6	Washer 6	1	1	1
G130	MS03A0703	アンナイホウ	Presser bar guide	1	1	1
G131	M93202047	トクシユナツト1/2(28)	Special nut 1/2(28)	1	1	1
G132	M93213035	ツマミネシ1/2(28)×43	Thumb screw 1/2(28)×43	1	1	1

㊦ 中押え機構 (Ⅱ)
PRESSER BAR LIFTING MECHANISM (Ⅱ)

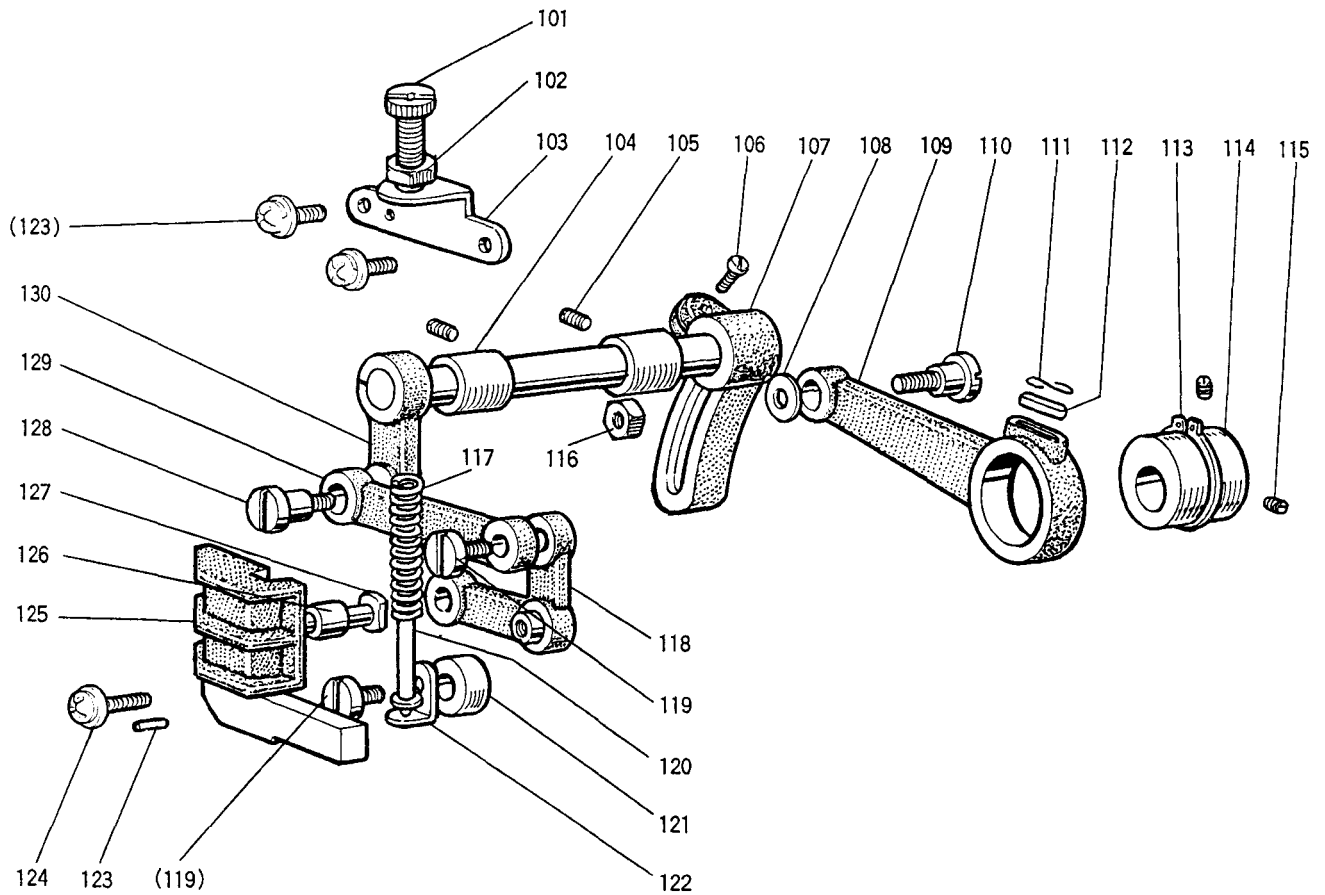

Fig No.	部品コード Parts No.	品名	Description	数量 Amt. Req.		
				B4516	B4516L	B6019
H101	M91801035	チヨウセツネシ ⁹ /32(28)×35	Adjusting screw 9/32(28)	1	1	1
H102	M91802045	ナツ9/32(28)	Nut 9/32(28)	1	1	1
H103	MG30B1261	オサエチヨウセツタイ	Presser regulating bracket	1	1	1
H104	MG30A0833	シ ⁹ ヨウフ ^シ ヨウケ ^メ タル	bushing	2	2	2
H105	M94006021	ロツカクアナツキトメネシ ^{M4} ×6	Screw M4×6	2	2	2
H106	M91603003	マルヒラネシ ^{1/4} (40)×16	Screw 1/4(40)×16	1	1	1
H107	MS07A0463	シ ⁹ ヨウフ ^シ ヨウケ ^オ クリウテ ^(ミキ)	Foot lifting rock shaft crank	1	1	1
H108	M90624050	サ ^カ ネ6	Washer 6	1	1	1
H109	MG30B0384	クランクロツト	Crank rod	1	1	1
H110	M91551015	トクシユホ ^ル ト	Special bolt	1	1	1
H111	MF60A0700	センサイクハ ^ネ	Spring	1	1	1
H112	MG30B0740	フェルト	Felt	1	1	1
H113	M90325065	C ^カ タメ ²⁵	C-type snap ring 25	1	1	1
H114	MG30A0760	ハンシンリン	Foot lifting eccentric	1	1	1
H115	M91606001	アタマナシトメネシ ^{1/4} (40)×6	Screw 1/4(40)×6	2	2	2
H116	M91572045	U ^{ナツ} 6×0.75	U-nut 6×0.75	1	1	1
H117	MS03A2572	ツルマキハ ^ネ	Spring	1	1	1
H118	MG10B0763	ベルクランク	Bell crank	1	1	1
H119	M91210002	ヒラネシ ^{3/16} (28)×10	Screw 3/16(28)×10	2	2	2
H120	MS03A6154	アンナイカ ^ネ クミタテ	Spring guide bar assy	1	1	1
H121	MS02A2352	ガラ	Collar	1	1	1
H122	MG30B0226	オサエイタササエ	Guide bar adapter	1	1	1
H123	M90301064	スプリング ^ヒ ン3×8	Spring pin 3×8	2	2	2
H124	M91054004	SW-PWツキ ^フ ラマイナ ^ハ ネシ ^{M4} ×8	Screw M4×8	4	4	4
H125	MS05A0765	ベルクランク ^カ イト	Bell crank guide	1	1	1
H126	MG10B0411	コロ	Roller	1	1	1
H127	M90507063	コロシ ^ク	Bell crank guide pin	1	1	1
H128	M91681015	タ ^ン ツキヒラネシ ^{1/4} (40)×12	Screw 1/4(40)×12	1	1	1
H129	MG10B0910	レンセツカン	Link	1	1	1
H130	MS02E0460	シ ⁹ ヨウフ ^シ ヨウケ ^ウ テ ^ク ミタテ ^{(ヒタ} リ)	Foot lifting rock shaft assy	1	1	1

J 糸切り機構
THREAD TRIMMING MECHANISM

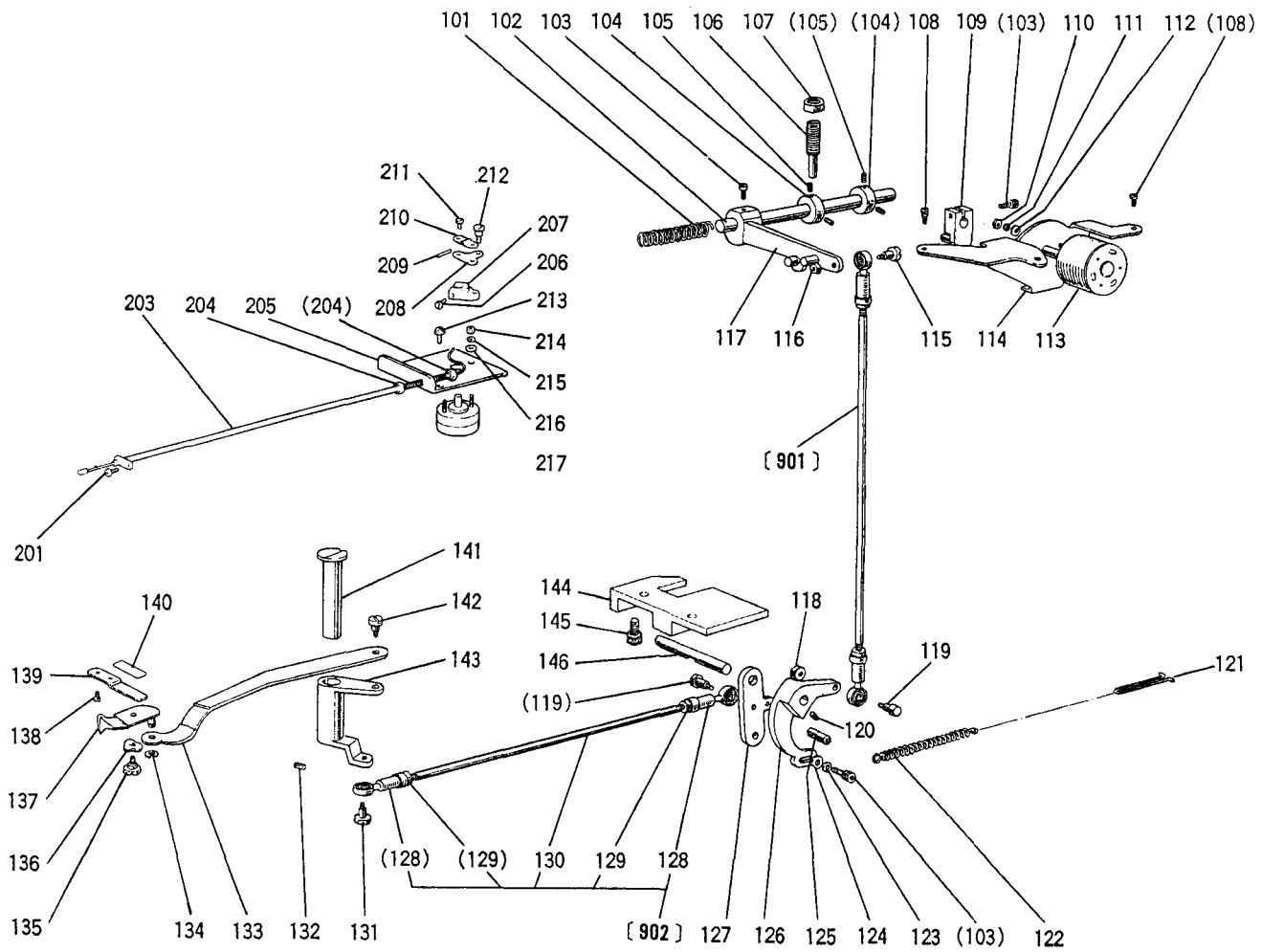

Fig No.	部品コード Parts No.	品名	Description	数量Amt. Req.		
				B4516	B4516L	B6019
J101	MS01A1572	ツルマキハネ	Spring	1	1	1
J102	MS01A0348	カムシク	Shaft	1	1	1
J103	M95003021	ロツカクアナツキホルトM5×12	Bolt M5×12	3	3	3
J104	MS01A3352	カラー	Collar	2	2	2
J105	M95004021	ロツカクアナツキトメネシM5×5	Screw M5×5	4	4	4
J106	M91504005	ホウサキトメネシ15/64(28)×32	Screw 15/64(28)×32	1	1	1
J107	M91503045	ナット15/64(28)	Nut15/64(28)	1	1	1
J108	M91056004	SW-PWツキフ°ラマイナハネシM4×10	Screw M4×10	3	3	3
J109	MS01E0430	イトキリサトウウテ	Crank complete	1	1	1
J110	M91003045	ナットM4	Nut M4	2	2	2
J111	M90401053	ハネサカネ4	Spring washer 4	2	2	2
J112	M90450050	サカネ4	Washer 4	2	2	2
J113	MB60E2519	ロータリソレノイトクミタテ(イトキリ)	Rotary solenoid assy	1	1	1
J114	MS14A3601	ソレノイトトリツケイタ	Solenoid adapter	1	1	1
J115	M91101015	タンツキヒラネシ11/64(40)	Screw 11/64(40)	1	1	1
J116	M91104045	ナット11/64(40)	Screw 11/64(40)	1	1	1
J117	MS01E0351	カムツイシユウウテクミタテ	Cam follower assy	1	1	1
J118	M91104045	ナット11/64(40)	Nut 11/64(40)	1	1	1
J119	M90101017	タンツキホルト11/64(40)	Bolt 11/64(40)	2	2	2
J120	M91108001	トメネシ11/64(40)×5.5	Screw 11/64(40)×5.5	1	1	1
J121	MS08A0708	ハネカケ	Hook	1	1	1
J122	MS01A2572	ツルマキハネ	Spring	1	1	1
J123	M90501053	ハネサカネ5	Spring washer 5	1	1	1
J124	M90550050	サカネ5	Washer 5	1	1	1
J125	M91109045	ナット11/64(40)	Nut 11/64(40)	1	1	1
J126	MS01A1392	メスクトウウテ	Knife driving crank	1	1	1
J127	MS01A2392	メスクトウウテ	Knife driving crank	1	1	1
J128	MN55A0975	ロッドエンド	Rod end bearing	2	2	2
J129	M91372045	ナットM5	Nut M5	2	2	2
J130	M95008023	ウエコミホルト	Stud bolt	1	1	1
J131	M91101017	タンツキホルト11/64(40)	Screw 11/64(40)	1	1	1
J132	M91222001	クホミサキトメネシM5×6	Screw M5×6	1	1	1
J133	MA20A1910	リンク	Link	1	1	1
J134	M90513065	エカトメワ2.5	Snap ring 2.5	1	1	1
J135	M91129015	タンツキヒラネシ11/64(40)	Screw 11/64(40)	1	1	1
J136	M96004052	ナミサカネ6	Wave washer 6	1	1	1
J137	MS03B0838	イトウメスクミタテ	Movable knife	1	1	1
J138	M90906003	マルヒラネシ9/64(40)×3.2	Screw 9/64(40)×3.2	2	2	2
J139	MS14A0838	コテイメス	Fixed knife	1	1	1
J140	MA10B2476	スペーサ(メスヨウ)	Spacer	1	1	1
J141	MB62A0454	ツハツクシク	Shoulder pin	1	1	1
J142	M91214015	タンツキヒラネシ3/16(28)	Screw 3/16(28)	1	1	1
J143	MA20A0392	メスクトウウテ	Knife driving crank	1	1	1
J144	MS14A3603	トリツケタイ	Bracket	1	1	1
J145	M96062021	ロツカクアナツキホルタンホルト M6×12	Bolt M6×12	2	2	2
J146	MS08A0454	シク	Shaft	1	1	1
J201	M91054004	SW-PWフ°ラマイナハネシM4×8	Screw M4×8	1	1	1
J203	MA20E0746	フレキシブルワイヤクミタテ	Flexible wire assy	1	1	1
J204	M92074045	ナットM5	Nut M5	2	2	2
J205	MA20A0603	ソレノイトトリツケタイ	Solenoid adapter	1	1	1
J206	M91112002	ヒラネシ11/64(40)×12	Screw 11/64(40)×12	1	1	1
J207	MS07A0228	ウテ	Crank	1	1	1
J208	MF90A0361	カケカネ	Bracket	1	1	1
J209	MN60A0750	フツシュ	Holder	1	1	1
J210	MF36A0750	フツシュ	Holder	1	1	1
J211	M90802002	ヒラネシ1/8(44)×7	Screw 1/8(44)×7	2	2	2
J212	M91127015	タンツキヒラネシ11/64(40)	Screw 11/64(40)	1	1	1
J213	M91067004	SW-PWツキフ°ラマイナハネシM5×10	Screw M5×10	2	2	2
J214	M91003045	ナットM4	Nut M4	2	2	2
J215	M90401053	ハネサカネ4	Spring washer 4	2	2	2
J216	M90450045	サカネ4	Washer 4	2	2	2
J217	MB60E5519	ロータリソレノイトクミタテ(イトルメ)	Rotary solenoid assy	1	1	1
J901	MS01E0975	ロッドエンドクミタテ	Connecting link assy	1	1	1
J902	MB45E0975	ロッドエンドクミタテ	Connecting link assy	1	1	1

K X-Yテーブル機構 (I)
 X-Y TABLE MECHANISM (I)

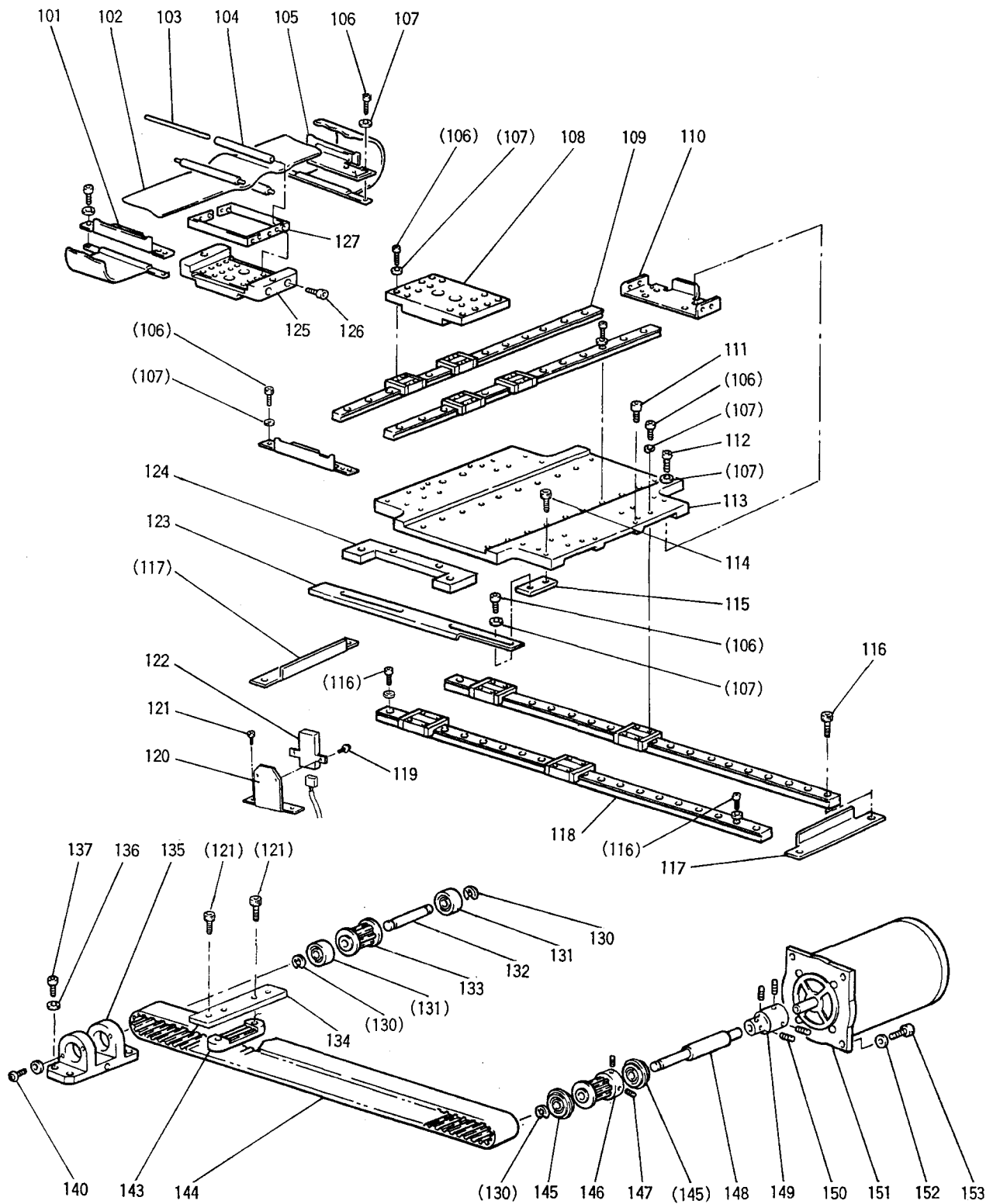

Fig No.	部品コード Parts No.	品名	Description	数量 Amt. Req.		
				B4516	B4516L	B6019
K101	MA45A0477	Yｼﾞｸｽﾄｯﾊﾟ	Y-Stopper	1	1	1
K102	MA45E0431	ｼｰﾄｶﾊﾞｰ(ｸﾐ)	Cover complete		1	1
K103	MA46A0971	ﾛｰﾗﾝｼﾞｸ	Shaft		3	3
K104	MA46A0972	ｼｰﾄﾛｰﾗ	Roller		3	3
K105	MA46A0477	Yｼﾞｸｽﾄｯﾊﾟ	Y-Stopper		1	1
K106	M94003017	ﾍﾌﾞﾃｲﾂｸﾞｯﾄ M3×6	Bolt M3×6	62	62	62
K107	M90317050	ｻﾞｶﾞﾈ 3	Washer 3	76	76	84
K108	MA45A0957	Yｼﾞｸｲﾄﾞﾞﾚｰｽ	Y-Movable race	1		
K109	MA20A2920	Yｼﾞｸﾘﾆｱｳｴｲ	Y-Linear way	2	2	2
K110	MA46A0477	Yｼﾞｸｽﾄｯﾊﾟ	Y-Stopper	1		
K111	M96001031	ｽﾊﾟｰｽﾎﾙﾄ	Spacer bolt	8	8	8
K112	M94004017	ﾍﾌﾞﾃｲﾂｸﾞｯﾄ M3×16	Bolt M3×16	4	4	4
K113	MB45A0957	Xｼﾞｸｲﾄﾞﾞﾚｰｽ	X-Movable race	1	1	1
K114	M94009017	ﾍﾌﾞﾃｲﾂｸﾞｯﾄ M3×12	Bolt M3×12	2	2	2
K115	MB45A0601	ﾄﾘｯｸｲﾀ	Adapter	2	2	2
K116	M94005037	ﾍﾌﾞﾃｲﾂｸﾞｯﾄ M3×10	Bolt M3×10	16	16	22
K117	MB45A0477	Xｼﾞｸｽﾄｯﾊﾟ	X-Stopper	2	2	2
K118	MA45A1920	Xｼﾞｸﾘﾆｱｳｴｲ	X-Linear way	2	2	
	MA61A1920	Xｼﾞｸﾘﾆｱｳｴｲ	X-Linear way			2
K119	M90861004	SW-PWﾌﾞﾗｲﾅﾊﾞｰﾈｼﾞ M3×8	Screw M3×8	2	2	2
K120	MB60A0408	ｹﾝｼﾞｭｯﾀﾞｲ	Adapter	1	1	1
K121	M94001017	ﾍﾌﾞﾃｲﾂｸﾞｯﾄ M4×10	Bolt M4×10	6	6	6
K122	MB60A0406	ｷﾝｾｯｽｲｯﾁ	Detector	1	1	1
K123	MB45A0407	Xｼﾞｸｹﾝｼﾞｭｯﾀ	Detector plate (X)	1	1	
	MB69A0407	Xｼﾞｸｹﾝｼﾞｭｯﾀ	Detector plate (X)			1
K124	MB45A1601	ﾄﾘｯｸｲﾀ	Adapter	1	1	1
K125	MA46A0957	Yｼﾞｸｲﾄﾞﾞﾚｰｽ	Y-Movable race		1	1
K126	M93003021	ﾛｸｶｶﾞﾅｯｷﾞﾎﾙﾄ M3×6	Bolt M3×6		4	4
K127	MA46A0359	ﾛｰﾗﾝｼﾞｸｶﾞｲﾄﾞ	Roller guide		1	1
K130	M96604065	Eｶﾞﾀﾄﾒ3	E-Type retaining ring 3	2	2	2
K131	M502A2456	ﾊﾞｰﾘﾝｸﾞ	Ball bearing	2	2	2
K132	MS13A5454	ｼﾞｸ	Shaft	1	1	1
K133	MB62A0767	ﾀｲﾐﾝｸﾞﾌﾟｰﾘ	Cog pulley	1	1	1
K134	MB45A2476	ｽﾊﾟｰｻ	Spacer	1	1	1
K135	MA45A2758	ﾌﾞﾗｯｹｯﾄ	Bracket	1	1	1
K136	M90511050	ｻﾞｶﾞﾈ 5	Washer 5	4	4	4
K137	M95001017	ﾍﾌﾞﾃｲﾂｸﾞｯﾄ M5×20	Bolt M5×20	4	4	4
K140	M91071004	SW-MWﾌﾞﾗｲﾅﾊﾞｰﾈｼﾞ M4×8	Screw M4×8	4	4	4
K143	MA45A0778	ﾊﾞﾙﾄｵｻﾞ	Belt clamper	1	1	1
K144	MB45A0523	ﾀｲﾐﾝｸﾞﾊﾞﾙﾄ	Cog belt	1	1	
	MB69A0523	ﾀｲﾐﾝｸﾞﾊﾞﾙﾄ	Cog belt			1
K145	M92010070	ﾊﾞｰﾘﾝｸﾞ	Ball bearing	2	2	2
K146	MB45A0767	ﾀｲﾐﾝｸﾞﾌﾟｰﾘ	Cog pulley	1	1	1
K147	M96001001	ﾛｸｶｶﾞﾅｯｷﾞﾄﾒｼﾞ M6×8	Screw M6×8	2	2	2
K148	MA45A0390	Xｸﾄﾞﾞｼﾞｸ	Drive shaft	1	1	1
K149	MA45A0571	ｯｷﾞﾃ	Sleeve	1	1	1
K150	M96002001	ﾛｸｶｶﾞﾅｯｷﾞﾄﾒｼﾞ M6×6	Screw M6×6	4	4	4
K151	M95045095	ｽﾃｯﾋﾞﾝｸﾞﾓｰﾀ(Xｼﾞｸ)	Motor complete (X)	1	1	1
K152	M90624050	ｻﾞｶﾞﾈ 6	Washer 6	4	4	4
K153	M96004017	ﾍﾌﾞﾃｲﾂｸﾞｯﾄ M6×20	Bolt M6×20	4	4	4

Fig No.	部品コード Parts No.	品名	Description	数量 Amt. Req.		
				B4516	B4516L	B6019
L101	M95046095	ステッピングモータ(Yｼｸ)	Motor complete (Y)	1	1	1
L102	M96004017	ﾍﾞﾝﾃﾞﾙ ﾍﾞﾙﾄ M6×20	Bolt M6×20	4	4	4
L103	M90624050	ｼﾞﾝ ﾍﾞﾙﾄ 6	Washer 6	4	4	4
L104	M91576045	ﾅｯﾄ M8	Nut M8	2	2	2
L105	M90803053	ﾊﾞｽﾞ ﾍﾞﾙﾄ 8	Spring washer 8	2	2	2
L106	MA45A0751	ﾌﾞﾛｯｸ	Block	2	2	2
L107	M95002017	ﾍﾞﾝﾃﾞﾙ ﾍﾞﾙﾄ M5×12	Bolt M5×12	4	4	4
L108	MA45A1390	ﾂ ﾍﾞﾙﾄ	Y-Drive shaft	2	2	2
L109	MS13A2454	ｼｸ	Shaft	2	2	2
L110	MS02A2456	ﾊﾞ ﾍﾞﾙﾄ	Ball bearing	8	8	8
L111	MS13A0767	ﾀｲﾐﾝｸﾞ ﾍﾞﾙﾄ	Cog pulley	2	2	2
L112	MS13A0758	ﾌﾞﾗｯｸﾞ	Bracket	2	2	2
L113	M90512050	ｼﾞﾝ ﾍﾞﾙﾄ 5	Washer 5	14	14	14
L114	M95011021	ﾛｯｸ ﾍﾞﾙﾄ M5×25	Bolt M5×25	2	2	2
L115	M90516065	ｼﾞﾝ ﾍﾞﾙﾄ Cﾀｲﾌﾟ 10	C-Type retaining ring 10	2	2	2
L116	MA61A0523	ﾀｲﾐﾝｸﾞ ﾍﾞﾙﾄ	Cog belt	2	2	2
L117	MA45A3758	ﾌﾞﾗｯｸﾞ	Bracket	2	2	2
L118	MA45A2390	ﾂ ﾍﾞﾙﾄ	Y-Drive shaft	1	1	1
L119	M95004017	ﾍﾞﾝﾃﾞﾙ ﾍﾞﾙﾄ M5×16	Bolt M5×16	8	8	8
L121	M91071004	SW-PW ﾍﾞﾙﾄ M4×10	Screw M4×10	4	4	4
L122	MB45A1767	ﾀｲﾐﾝｸﾞ ﾍﾞﾙﾄ	Cog pulley	2	2	2
L123	M96001001	ﾛｯｸ ﾍﾞﾙﾄ M6×8	Screw M6×8	4	4	4
L125	MA45A1571	ｽﾘｰﾌ	Sleeve	1	1	1
L126	M96002001	ﾛｯｸ ﾍﾞﾙﾄ M6×6	Screw M6×6	4	4	4
L127	MA45A0921	ﾘﾆｱ ﾍﾞﾙﾄ	Bearing	2	2	2
L128	MA45A1921	ﾘﾆｱ ﾍﾞﾙﾄ	Bearing	2	2	2
L129	M96061021	ﾛｯｸ ﾍﾞﾙﾄ M6×20	Bolt M6×20	2	2	2
L130	M90624053	ﾊﾞｽﾞ ﾍﾞﾙﾄ 6	Spring washer 6	2	2	2
L131	MA46A0781	Y ﾍﾞﾙﾄ ﾍﾞﾙﾄ (L)	Y-Belt holder (L)	1	1	1
L132	M94001017	ﾍﾞﾝﾃﾞﾙ ﾍﾞﾙﾄ M4×10	Bolt M4×10	4	4	4
L133	M90422050	ｼﾞﾝ ﾍﾞﾙﾄ 4	Washer 4	4	4	4
L134	MA45A1781	ﾊﾞ ﾍﾞﾙﾄ (Y)	Belt clasper (Y)	2	2	2
L135	M95001017	ﾍﾞﾝﾃﾞﾙ ﾍﾞﾙﾄ M5×20	Bolt M5×20	4	4	4
L136	M91119602	ﾍﾞﾙﾄ (40)×6.8	Screw (40)×6.8	4	4	4
L140	M91058004	SW-PW ﾍﾞﾙﾄ M4×6	Screw M4×6	6	6	6
L141	MB45A2601	ﾄﾘｯｸ ﾍﾞﾙﾄ	Adjuster plate	1	1	1
L142	MB45A3601	ｸﾞ ﾍﾞﾙﾄ	Adapter	1	1	1
L143	MB60A0406	ｷﾝ ﾍﾞﾙﾄ	Detector	1	1	1
L144	M90861004	SW-PW ﾍﾞﾙﾄ M3×8	Screw M3×8	2	2	2
L145	MA45A5758	ﾌﾞﾗｯｸﾞ	Bracket	1	1	1
L146	MB45A0390	ﾂ ﾍﾞﾙﾄ	Y-Drive shaft	1	1	1
L147	MB45A0364	ｶｯﾌﾟ ﾍﾞﾙﾄ	Coupling	1	1	1
L148	MB45A1407	ｼﾞﾝ ﾍﾞﾙﾄ	Detector plate (Y)	1	1	1
L149	MA46A2781	Y ﾍﾞﾙﾄ ﾍﾞﾙﾄ (R)	Y-Belt holder (R)	1	1	1

M 外押え機構
WORK HOLDER MECHANISM

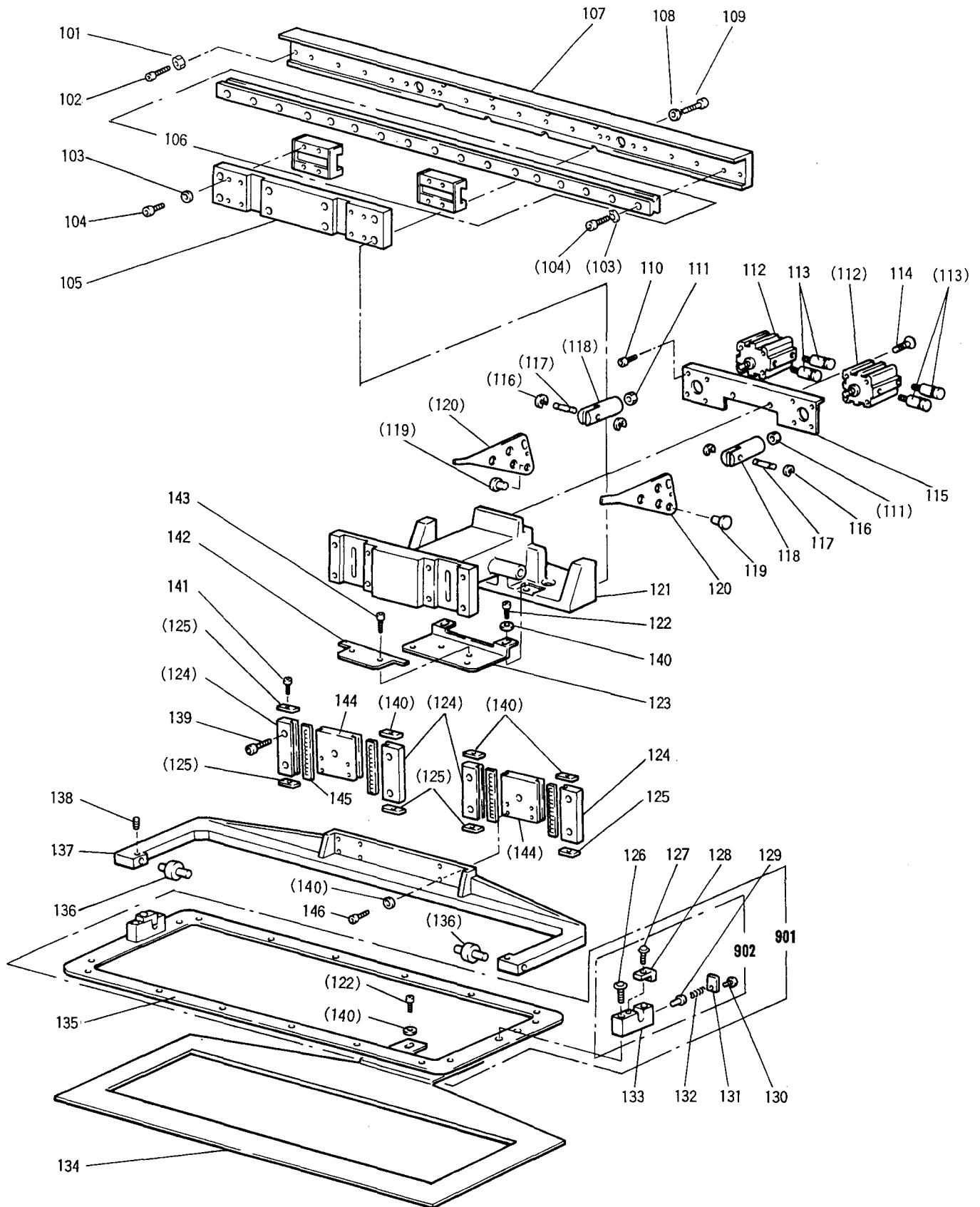

Fig No.	部品コード Parts No.	品名	Description	数量 Amt. Req.		
				B4516	B4516L	B6019
M101	M91372045	ナット M5	Nut M5	2	2	2
M102	M94015021	ロクカクアナツキホルト M4×20	Bolt M4×20	2	2	2
M103	M90317050	サカネ 3	Washer 3	23	23	27
M104	M94004017	セフティソケット M3×16	Bolt M3×16	23	23	27
M105	MA45A1601	トリツケイタ	Adapter	1	1	1
M106	MB45A0920	リニアウェイ	Linear way	1	1	
	MB69A0920	リニアウェイ	Linear way			1
M107	MA45A0455	シクササエ	Shaft holder	1	1	
	MA61A0455	シクササエ	Shaft holder			1
M108	M90512050	コサカネ 5	Washer 5	8	8	8
M109	M95001017	セフティソケット M5×20	Bolt M5×20	8	8	8
M110	M96002017	セフティソケット M6×12	Bolt M6×12	2	2	2
M111	M92075045	ナット M8	Nut M8	2	2	2
M112	MA45A0434	エアシリンダ	Air cylinder	2	2	2
M113	MS10A3571	ワナツチツキテ	Connector	4	4	4
M114	M94001017	セフティソケット M4×10	Bolt M4×10	2	2	2
M115	MA45A2601	トリツケイタ	Adapter	1	1	1
M116	M90512065	Eカタメワ3	E-Type retaining ring 3	4	4	4
M117	M90327060	ピンφ3	Pin φ3	2	2	2
M118	MA45A0621	ナツクル	Knuckle	2	2	2
M119	MS37A0454	ツハツキシク	Shaft	2	2	2
M120	MA45A0266	オサエレバ	Pushing lever	2	2	2
M121	MA45A0308	オサエタイ	Clamp bracket	1	1	1
M122	M95005017	セフティソケット M5×10	Bolt M5×10	2	2	2
M123	MA45A3601	トリツケイタ	Adapter	1	1	1
M124	MS13A8957	コチレース	Fixed race	4	4	4
M125	MS13A2477	ストツハ	Stopper	8	8	8
M126	M91056004	SW-PW7°ラマイナヘネジ M4×10	Screw M4×10	4	4	4
M127	M91273004	SW-PW7°ラマイナヘネジ M4×16	Screw M4×16	2	2	2
M128	MA45A2196	セツイタ	Bracket	2	2	2
M129	M90611060	ピン	Pin	2	2	2
M130	M90859004	SW-PW7°ラマイナヘネジ M3×6	Screw M3×6	2	2	2
M131	MS02B0257	オサエイタ	Adapter	2	2	2
M132	MS13A0572	ツルマキハネ	Spring	2	2	2
M133	MA45A7426	サエ	Supporter	2	2	2
M134	MA45A0272	オクリイタ	Feed plate	1		
	MA46A0272	オクリイタ	Feed plate		1	
	MA61A0272	オクリイタ	Feed plate			1
M135	MA45A0105	リトオサエ	Clamp frame	1		
	MA46A0105	リトオサエ	Clamp frame		1	
	MA61A0105	リトオサエ	Clamp frame			1
M136	MS02A2454	オサエシク	Clamp stud	2	2	2
M137	MA45A0273	オサエウテ	Clamp pad	1	1	
	MA61A0273	オサエウテ	Clamp pad			1
M138	M94006021	ロクカクアナツキホルト M4×6	Bolt M4×6	2	2	2
M139	M94002017	セフティソケット M4×8	Bolt M4×8	8	8	8
M140	M90511050	ミカキサカネ 5	Washer 5	12	12	12
M141	M94016021	ロクカクアナツキホルタンホルト M4×8	Bolt M4×8	8	8	8
M142	MA45A0196	セツイタ	Adapter	1	1	1
M143	M94008017	セフティソケット M4×6	Bolt M4×6	2	2	2
M144	MB45A1957	イトウレース	Movable race	2	2	2
M145	M94008070	スライトベアリング	Slide bearing	4	4	4
M146	M95004017	セフティソケット M5×16	BOLT M5×16	8	8	8
M901	MA45E0105	リトオサエ(クミ)	Clamp frame assy.	1		
	MA46E0105	リトオサエ(クミ)	Clamp frame assy.		1	
	MA61E0105	リトオサエ(クミ)	Clamp frame assy.			1
M902	MA45E0426	サエ(クミ)	Supporter complete	2	2	2

N
 ワイパー機構・上軸検出機構
 WIPER MECHANISM · UPER SHAFT DETECTION MECHANISM

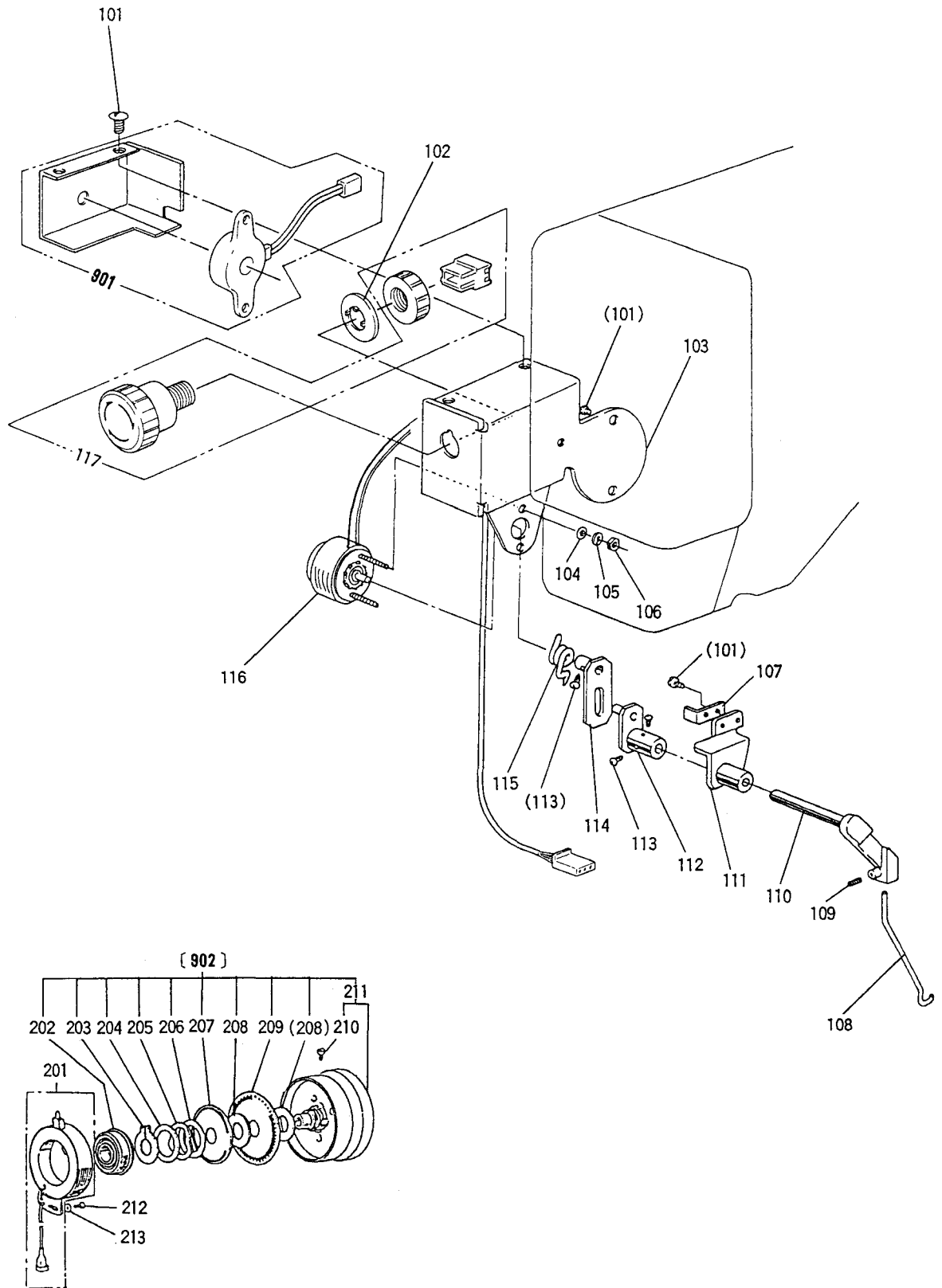

Fig No.	部品コード Parts No.	品名	Description	数量Amt. Req.		
				B4516	B4516L	B6019
N101	M91054004	SW-PWツキフ°ラマイナハ°ネジ°M4×8	Screw M4×8	7	7	7
N102	MB60A0915	マワリト°メリング°	Snap ring	1	1	1
N103	MB60E7601	トリツウイタ(シールツキ)	Bracket	1	1	1
N104	M90316050	サ°カ°ネ3	Washer 3	2	2	2
N105	M90307053	ハ°ネサ°カ°ネ3	Spring washer 3	2	2	2
N106	M90875045	ナツトM3	Nut M3	2	2	2
N107	MS02A1477	ストッパ°	Stopper	1	1	1
N108	MA20A0980	ワイハ°	Wiper	1	1	1
N109	M91057020	ロツカクアナツキトメネジ°M3×4	Screw M3×4	1	1	1
N110	MS03A1530	ワイハ°-シク	Wiper shaft	1	1	1
N111	MS10A0982	ワイハ°-タ°イ	Wiper adapter	1	1	1
N112	MS02E0981	ワイハ°-ウテ°	Wiper clank	1	1	1
N113	M90802003	マルヒラネシ°1/8(44)×4.5	Screw 1/8(44)×4.5	4	4	4
N114	MS02E0983	ク°ウイタ	Wiper clank	1	1	1
N115	MS02A4729	ヒネリハ°ネ	Spring	1	1	1
N116	MB45E0148	ロータリソレノイド°クミタテ	Rotary solenoid assy	1	1	1
N117	MB60E0270	オシホ°タンスイッチクミタテ	Halt switch assy	1	1	1
N901	MB60E3339	カハ°-クミタテ(フ°サ°-ツキ)	Cover assy (with buzzer)	1	1	1
N201	MB60A2406	センサー	Detector bracket assy	1	1	1
N202	MN70A0456	シクウケ	Ball bearing	1	1	1
N203	M90330065	Cカ°タトメワ30	Retaining ring C-type 30	1	1	1
N204	M93001050	サ°カ°ネ	Washer	1	1	1
N205	MF01A0259	ハンジャハ°ンオサエス°フ°リンク°	Wave washer	1	1	1
N206	MF01A1476	スハ°-サB	Spacer B	1	1	1
N207	MN72A1694	ハンジャハ°ンF20(ウエ)	Speed command disk F20 (up)	1	1	1
N208	MF01A0476	スハ°-サA	Spacer A	2	2	2
N209	MB60A0694	ハンジャハ°ンK10(シタ)	Speed command disk K10 (down)	1	1	1
N210	M91520002	ヒラネシ°15/64(28)×12	Screw 15/64(28)×12	2	2	2
N211	MB60E0682	フ°-リクミタテ	Pulley assy	1	1	1
N212	M91069004	フ°ラマイナハ°ネジ° M4×8	Screw M4×8	1	1	1
N213	M93002050	サ°カ°ネ	Washer	1	1	1
N902	MB60E1682	フ°-リクミタテ	Pulley assy	1	1	1

P 給油機構
OIL LUBRICATION MECHANISM

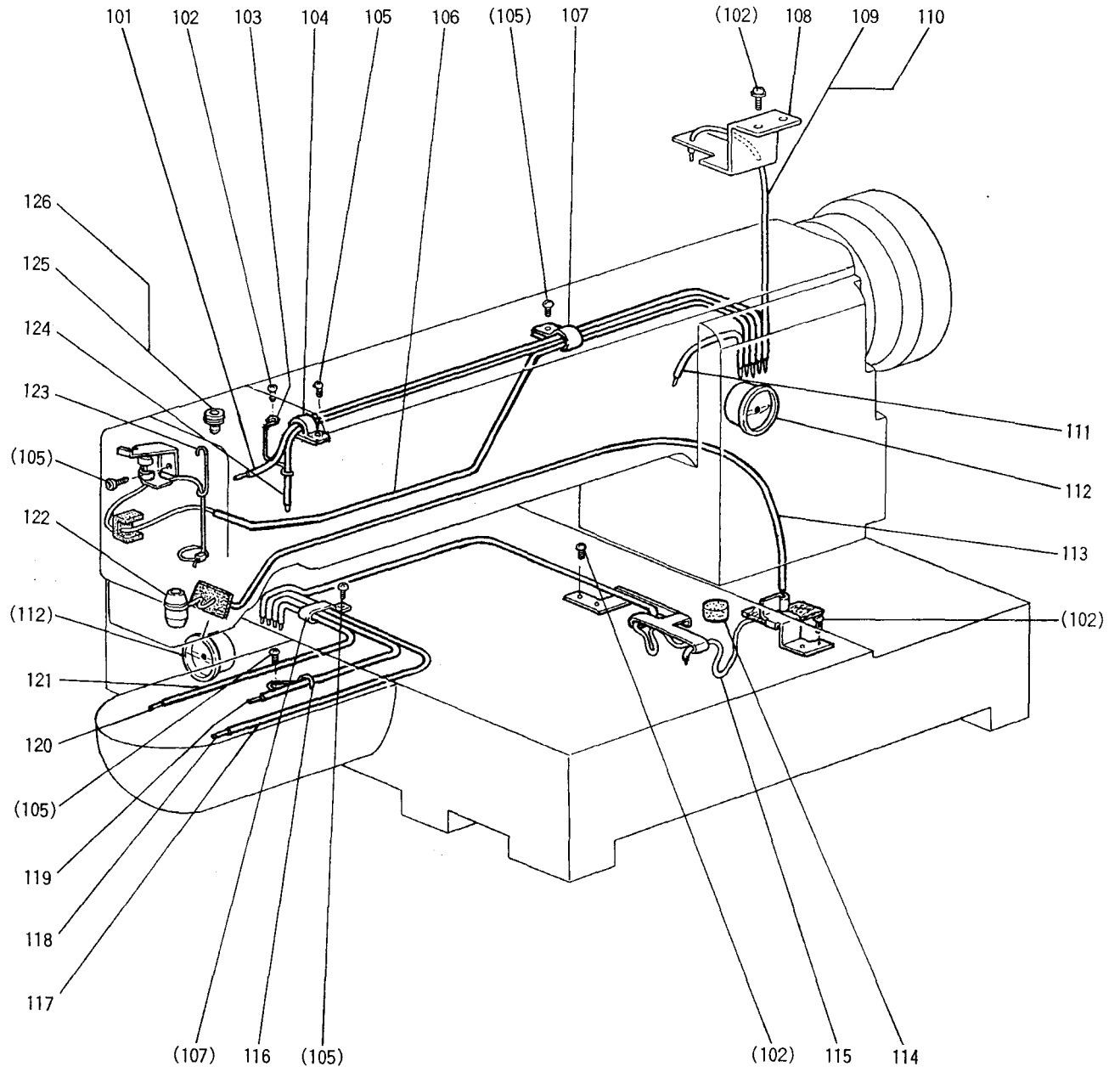

Fig No.	部品コード Parts No.	品名	Description	数量 Amt. Req.		
				B4516	B4516L	B6019
P101	MB45E0148	ハ°イフ°ヒモクミタテ	Oil pipe complete	1	1	1
P102	M91058004	SW-PWフ°ラマイナハ°ネジ° M4×6	Screw M4×6	8	8	8
P103	MA20A1780	ホルタ°-	Holder	1	1	1
P104	MA20A0620	ナイロンクリツフ°	Nylon clip	1	1	1
P105	M91054004	SW-PWフ°ラマイナハ°ネジ° M4×8	Screw M4×8	4	4	4
P106	MB45A0780	ホルタ°-クミタテ	Holder complete	1	1	1
P107	MS47P0620	ナイロンクリツフ°	Nylon clip	2	2	2
P108	MB60A1780	ホルタ°-	Holder	1	1	1
P109	MB60A1688	ハ°イフ°	Pipe	1	1	1
P110	MB45A0148	ヒモ	String	1	1	1
P111	MA20E2688	ハ°イフ°ヒモクミタテ	Oil gauge	1	1	1
P112	MN10A0135	アフ°ラマト°	Oil gauge	2	2	2
P113	MB45E2148	アフ°ラヒモクミタテ	String complete	1	1	1
P114	MF60A5740	フェルト	Felt	1	1	1
P115	MB45A1780	ホルタ°-クミタテ	Holder complete	1	1	1
P116	MS01A8796	ホルタ°-	Holder	1	1	1
P117	MB45A0688	ハ°イフ°(ミキ°)	Pipe (right)	1	1	1
P118	MB45A1148	ヒモ(ミキ°)	String (right)	1	1	1
P119	MB45E1148	ハ°イフ°ヒモクミタテ	Oil pipe complete	1	1	1
P120	MB45A2148	ヒモ(ヒタ°リ)	String (left)	1	1	1
P121	MB45A1688	ハ°イフ°(ヒタ°リ)	Pipe (left)	1	1	1
P122	MF00A1780	ホルタ°-	Holder	1	1	1
P123	MS03A2780	ホルタ°-	Holder	1	1	1
P124	MB45E2148	ハ°イフ°ヒモクミタテ	Oil pipe complete	1	1	1
P125	MF60A0742	フタ	Cap	1	1	1
P126	MF10A2740	フェルト	Felt	1	1	1

Q
 配線・配管関係
 CABLE COMPONENT & PNEUMATIC CONTROL UNIT

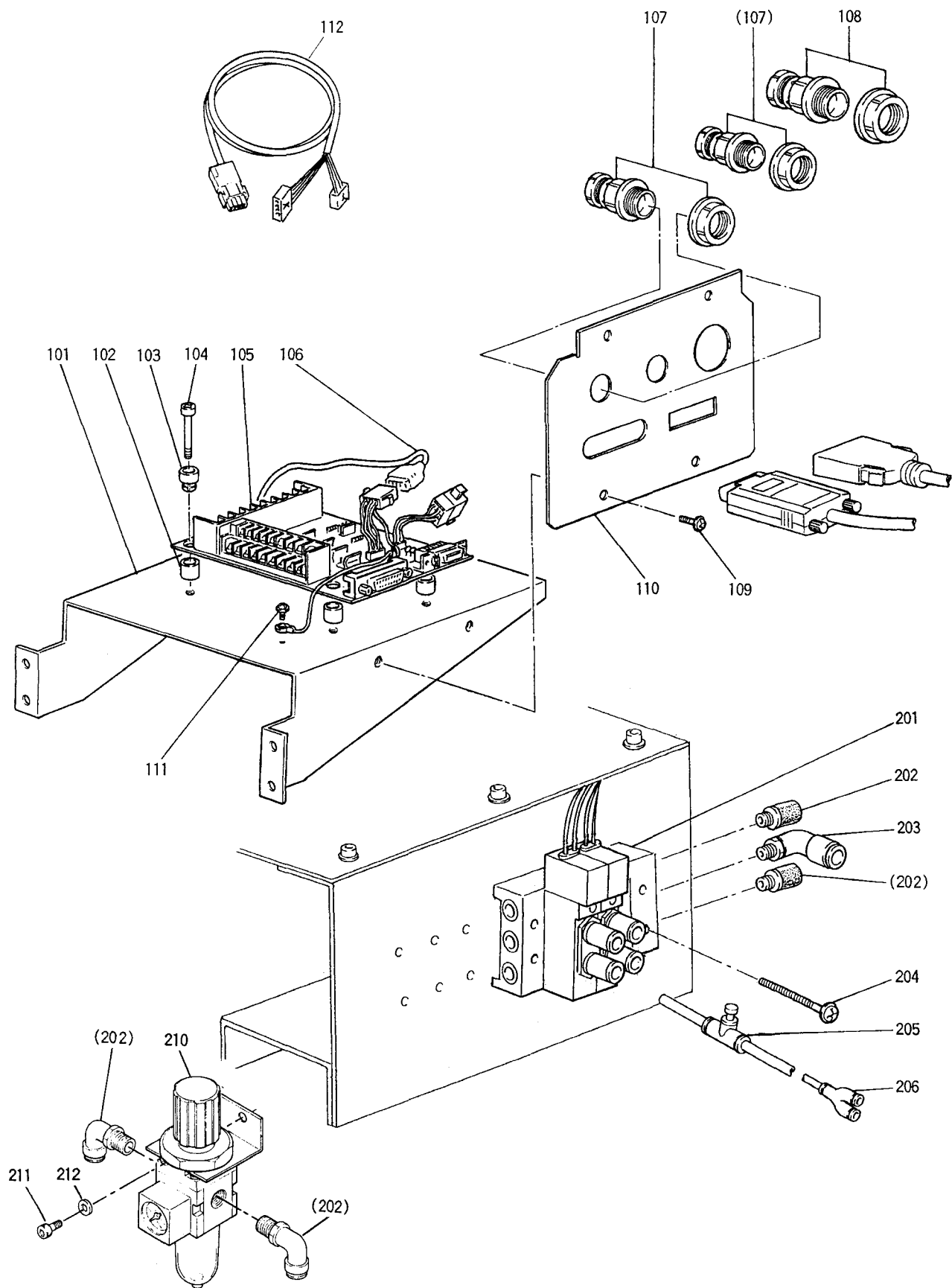

Fig No.	部品コード Parts No.	品名	Description	数量Amt. Req.		
				B4516	B4516L	B6019
Q101	MB45A3601	アダプター	Adapter	1	1	1
Q102	MB60A2352	スペーサ	Spacer	4	4	4
Q103	MB60A0366	キャップ	Screw adapter	4	4	4
Q104	M91057004	SW-PW7°ラマイナハネジ M4×20	Screw M4×20	4	4	4
Q105	M95003096	プリント基板	Print circuit board	1	1	1
Q106	K14M71725402	ケーブル(サーボエンコーダ)	Cable (servo encoder)	1	1	1
Q107	MB60A3780	コードフック	Cord holder	2	2	2
Q108	MB60A4780	コードフック	Cord holder	1	1	1
Q109	M91054004	SW-PW7°ラマイナハネジ M4×8	Screw M4×8	6	6	6
Q110	MB45A4601	コネクタリットケイタ	Connector panel	1	1	1
Q111	M90439037	SWツキナハネジ M4×8	Screw M4×8	1	1	1
Q112	M97324099	ケーブル(ステッピングモータ)	Cable (Stepping motor)	1	1	1
Q201	MB45E0599	ソレノイドバルブ	Solenoid valve complete	1	1	1
Q202	M91035089	サイレンサ	Muffler	2	2	2
Q203	MA20A8571	Lカッター	Connector	3	3	3
Q204	M91076004	SW-PW7°ラマイナハネジ M4×30	Screw M4×30	4	4	4
Q205	M92209098	スピードコントローラ	Speed controller	1	1	1
Q206	MA20A6571	Yカッター	Connector	1	1	1
Q210	MB61A0963	フィルタレギュレータ	Filter regulator	1	1	1
Q211	M95003017	セフテイルケット M5×8	Bolt M5×8	2	2	2
Q212	M90511050	ミカキサカネ 5	Washer 5	2	2	2

R テーブル関係
 TABLE & STAND

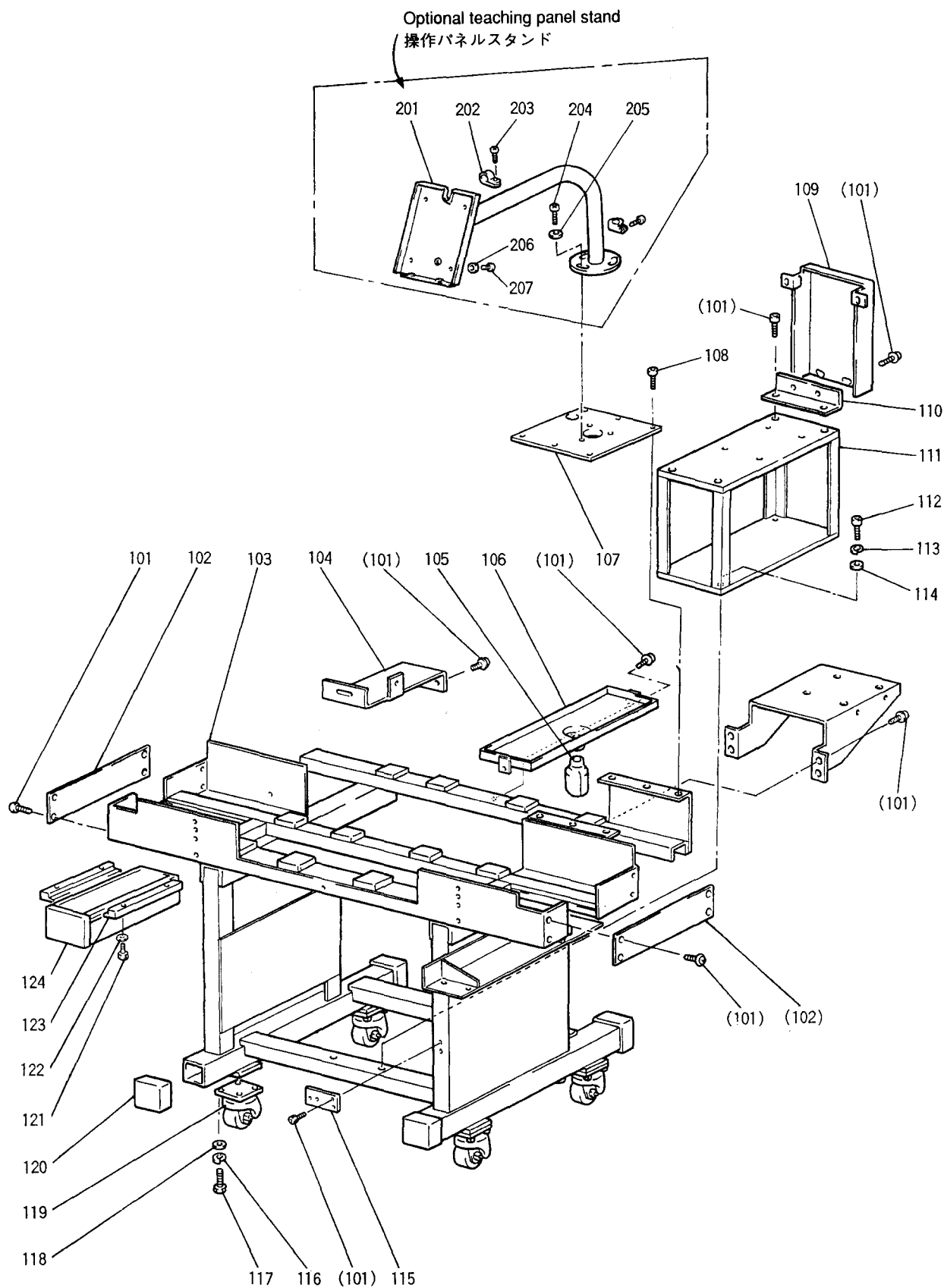

Fig No.	部品コード Parts No.	品名	Description	数量 Amt. Req.		
				B4516	B4516L	B6019
R101	M94013017	セフティソケット M4×12	Bolt M4×12	22	22	22
R102	MB45A3339	カバー	Cover	2	2	2
R103	MB45E0150	キャクミタテ	Leg complete	1	1	
	MB69E0150	キャクミタテ	Leg complete			1
R104	MB45A2339	カバー	Cover	1	1	1
R105	MF20A0130	アブラビン	Oil bottle	1	1	1
R106	MB45A0139	オイルパン	Oil pan	1	1	1
R107	MB45A5601	スタントトリツケイタ	Adapter	1	1	1
R108	M95010017	セフティソケット M5×12	Bolt M5×12	6	6	6
R109	MB45A0776	ベルトカバー	Belt cover	1	1	1
R110	MA35B7601	ベルトカバートリツケイタ	Adapter	1	1	1
R111	MB45A0603	モータトリツケイタ	Motor adapter	1	1	1
R112	M96009021	ロックアナツキボルト M6×16	Bolt M6×16	4	4	4
R113	M90624053	ハネサカネ 6	Spring washer 6	4	4	4
R114	M90624050	サカネ 6	Washer 6	4	4	4
R115	MB45A6601	トリツケイタ	Adapter	1	1	1
R116	M91003053	ハネサカネ 10	Spring washer 10	16	16	16
R117	M91016022	ロックボルト M10×25	Bolt M10×25	16	16	16
R118	M91012050	サカネ 10	Washer 10	16	16	16
R119	MB45E0972	キャスタ	Castor	4	4	4
R120	MB45A0150	ゴムキャク	Toe cap	4	4	4
R121	M93013021	ロックアナツキボルト M3×20	Screw M3×20	4	4	4
R122	M90316050	サカネ 3	Washer 3	4	4	4
R123	MA20A0719	ヒキタシ	Drawer	1	1	1
R124	MA20A4957	レール	Rail	2	2	2
R201	MA35E0483	ソウサスタント(オプション)	Operation stand (optional)	1	1	1
R202	MA20A2620	ナイロンクリップ	Nylon clip	2	2	2
R203	M91069004	プラマイナハネシ M4×8	Screw M4×8	2	2	2
R204	M91558022	ロックボルト M6×45	Bolt M6×45	3	3	3
R205	M90624050	サカネ 6	Washer 6	15	15	15
R206	M91606022	ロックボルト M3×10	Bolt M3×10	4	4	4
R207	M90316050	サカネ 3	Washer 3	4	4	4

S 付属品
ACCESSORIES

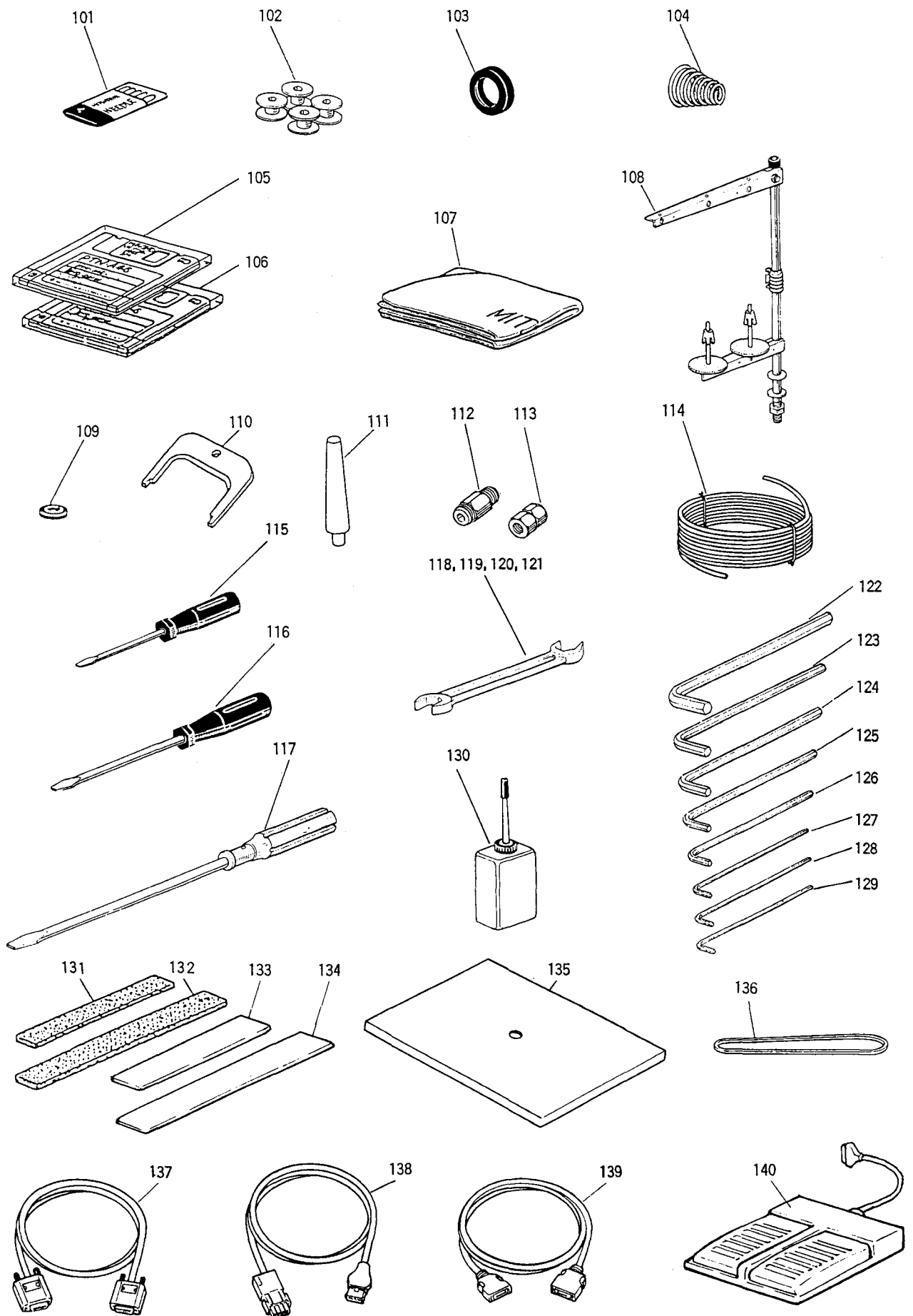

Fig No.	部品コード Parts No.	品名	Description	数量 Amt. Req.		
				B4516	B4516L	B6019
S101	MS02A0128	ミシンハ*リ DP×17#18	Needle DP×17#18	4	4	4
S102	MA10A0123	ホ*ビ*ン(SC-180ヨウ)	Bobbin (for SC-180)	3	3	3
S103	MS03A0417	コ*ムワ	Tire	1	1	1
S104	MN52A1245	エンシイハ*ネ	Tension spring	1	1	1
S105	MB60A0990	フロッピ*イテ*ィスク(システム)	Floppy disk (system)	1	1	1
S106	MB60A1990	フロッピ*イテ*ィスク(テ*ータホリ*ンヨウ)	Floppy disk (blank)	1	1	1
S107	MA20A0734	ヒ*ニルカハ*	Polyethylene cover	1	1	1
S108	MF40E0193	イトタテ*イクミタテ	Cotton stand assy.	1	1	1
S109	MB60A0419	ホ*ウシ*ンコ*ム	Rubber cushion	6	6	6
S110	MF01A0565	カク*チヨウセイク*	Disk adjusting plate	1	1	1
S111	MA20A0613	トウフ*ウケ	Head rest	1	1	1
S112	MA30A0571	ワンタッチツキ*テ	Quick joint	1	1	1
S113	M91010089	ロツカカリソケット	Socket	1	1	1
S114	MA17A0567	チューフ*	Tube	1	1	1
S115	MB02A1608	ト*ライハ*(シヨウ)	Screw driver (small)	1	1	1
S116	MB02A0608	ト*ライハ*(チュウ)	Screw driver (middle)	1	1	1
S117	MF00A0608	ト*ライハ*(タ*イ)	Screw driver (large)	1	1	1
S118	MS02A0479	リヨウク*チスハ*ナ13×17	Spanner 13×17	1	1	1
S119	MM10A1479	リヨウク*チスハ*ナ10×14	Spanner 10×14	1	1	1
S120	MS10A1976	リヨウク*チスハ*ナ8×9	Spanner 8×9	1	1	1
S121	MS10A2976	リヨウク*チスハ*ナ6×7	Spanner 6×7	1	1	1
S122	MS05A1976	ロツカクホ*ウスハ*ナ6	Socket wrench 6	1	1	1
S123	MS05A0976	ロツカクホ*ウスハ*ナ5	Socket wrench 5	1	1	1
S124	MS01A1976	ロツカクホ*ウスハ*ナ4	Socket wrench 4	1	1	1
S125	MF90A0976	ロツカクホ*ウスハ*ナ1/8	Socket wrench 1/8	1	1	1
S126	MS02A2976	ロツカクホ*ウスハ*ナ3	Socket wrench 3	1	1	1
S127	MS02A1976	ロツカクホ*ウスハ*ナ2.5	Socket wrench 2.5	1	1	1
S128	MS02A0976	ロツカクホ*ウスハ*ナ2	Socket wrench 2	1	1	1
S129	MS10A0976	ロツカクホ*ウスハ*ナ1.5	Socket wrench 1.5	1	1	1
S130	MF10A0149	アフ*ラサシ	Oiler with oil	1	1	1
S131	MA45A0691	ハ*ツキン(シタオサエイタヨウ)	Clamp pad (for feed plate)	2		
S131	MA61A0691	ハ*ツキン(シタオサエイタヨウ)	Clamp pad (for feed plate)		2	2
S132	MA45A1691	ハ*ツキン(シタオサエイタヨウ)	Clamp pad (for feed plate)	2	2	
S132	MA61A1691	ハ*ツキン(シタオサエイタヨウ)	Clamp pad (for feed plate)			2
S133	MA45A0416	ハ*ツキン(リトオサエイヨウ)	Clamp pad (for clamp frame)	4		
S133	MA61A0416	ハ*ツキン(リトオサエイヨウ)	Clamp pad (for clamp frame)		4	4
S134	MA45A1416	ハ*ツキン(リトオサエイヨウ)	Clamp pad (for clamp frame)	4	4	
S134	MA61A1416	ハ*ツキン(リトオサエイヨウ)	Clamp pad (for clamp frame)			4
S135	MB62A0797	ホコ*フィルム	Film sheet	1	1	
S135	MB63A0797	ホコ*フィルム	Film sheet			1
S136	MA20A0777	V*ヘルト M46	V-belt M52	1	1	1
S137	M97320099	ケーフ*ル(ソレノイド*)	Cable (out of solenoid)	1	1	1
S138	M97318099	ケーフ*ル(サーボ*モータ*ンゲン)	Cable (servo motor)	1	1	1
S139	M97319099	ケーフ*ル(ニューリヨクシ*ンコ*ウ)	Cable (input signal)	1	1	1
S140	M860A0FSW	フットスイッチ	Foot switch	1	1	1

☐ オプションパーツ
OPTION PARTS

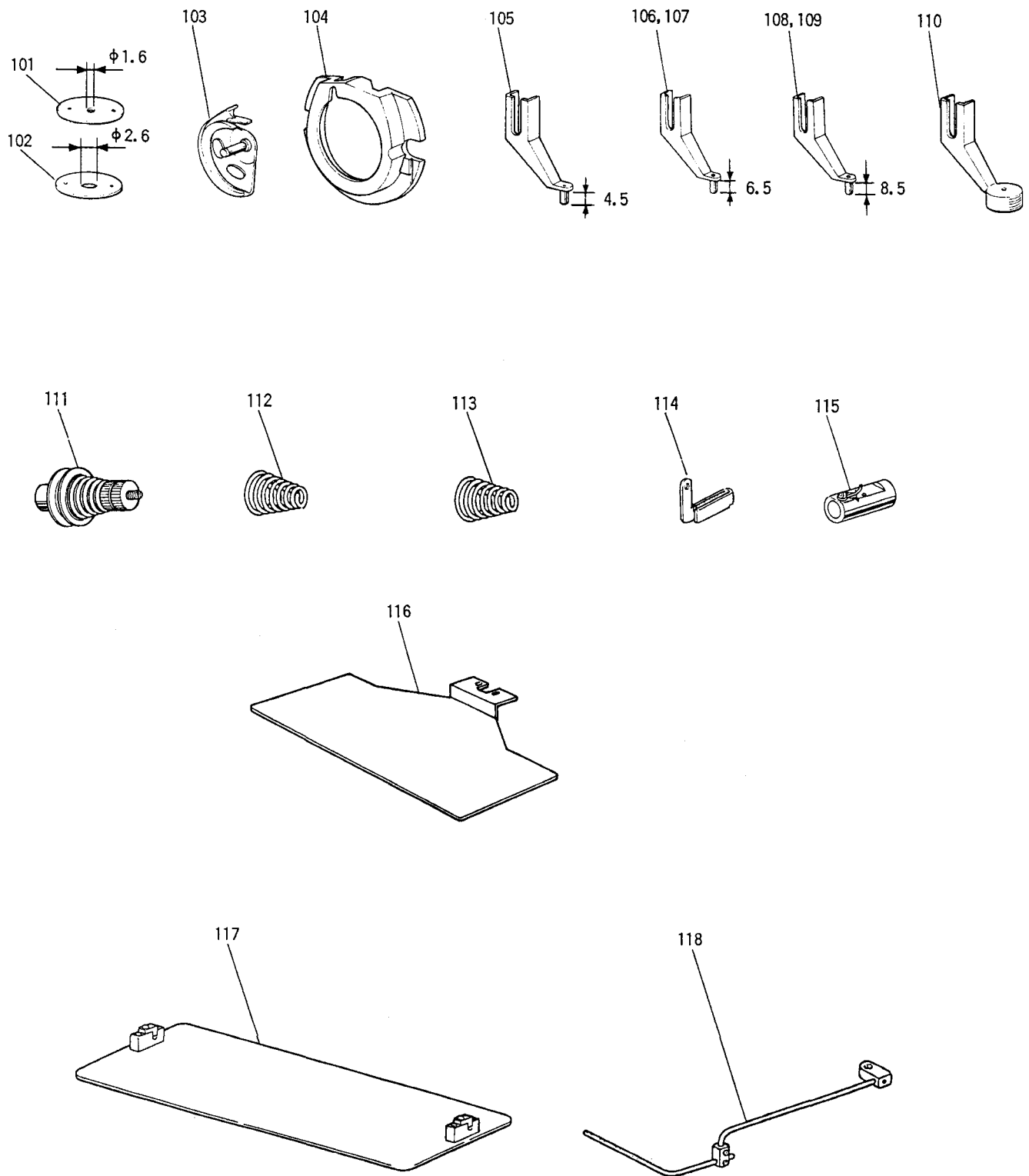

Fig No.	部品コード Parts No.	品名	Description	数量 Amt. Req.		
				B4516	B4516L	B6019
T101	MS03A0101	ハリイタ(φ1.6)	Needle plate (φ1.6)	1	1	1
T102	MS03A2101	ハリイタ(φ2.6)	Needle plate (φ2.6)	1	1	1
T103	MS17A1120	ナカカマD(アツモ/ヨウ)	Inner hook D (for heavy)	1	1	1
T104	MS01A1616	ナカカマオサエ(アツモ/ヨウ)	Inner hook clamber(for heavy)	1	1	1
T105	MV30A1256	ナカオサエ(φ2)	Presser foot (φ2)	1	1	1
T106	MS03A0256	ナカオサエ(φ3)	Presser foot (φ3)	1	1	1
T107	MS03A1256	ナカオサエ(φ2)	Presser foot (φ2)	1	1	1
T108	MA35A0256	ナカオサエ(φ3)	Presser foot (φ3)	1	1	1
T109	MA35A1256	ナカオサエ(φ2)	Presser foot (φ2)	1	1	1
T110	MV35A0106	サラオサエ(φ3)	Presser foot (φ3)	1	1	1
T111	MS04E1210	ウワイトチヨウセツキミタテ	Thread tension regulator assy	1	1	1
T112	MF10A1245	エンスイハネ(フ°リテンション)	Thread pretension spring	1	1	1
T113	MN10A3245	エンスイハネ(ウワイトチヨウセツキ)	Tension regulator spring	1	1	1
T114	MS03A0181	イトアンナイクミタテ	Thread guide assy	1	1	1
T115	MS10A0180	イトアンナイクミタテ	Thread guide assy	1	1	1
T116	MA45A1272	ソトオサエイタ(アナナシ)	Feed plate(blank)	1		
T117	MA46A1272	ソトオサエイタ(アナナシ)	Feed plate(blank)		1	
T118	MA61A1272	ソトオサエイタ(アナナシ)	Feed plate(blank)			1
T119	MA45E1105	ソトオサエクミ(アナナシ)	Clamp frame assy. (blank) ...	1		
T120	MA46E1105	ソトオサエクミ(アナナシ)	Clamp frame assy. (blank) ...		1	
T121	MA61E1105	ソトオサエクミ(アナナシ)	Clamp frame assy. (blank) ...			1
T122	MA35A0180	イトアンナイクミタテ	Thread guide assy	1	1	1